

Instructions

- The test is of 3 hours duration.
- The Test Booklet consists of 90 questions. The maximum marks are 432.
- There are three parts in the question paper. The distribution of marks subject wise in each part is as under for each correct response.
Part A - PHYSICS (144 marks) – Questions No. 1 to 2 and 9 to 30 consist FOUR (4) marks each and Question No. 3 to 8 consist EIGHT(8) marks each for each correct response.
Part B - CHEMISTRY (144 marks) – Questions No. 31 to 39 and 46 to 60 consist FOUR (4) marks each and Question No. 40 to 45 consist EIGHT (8) marks each for each correct response.
Part C - MATHEMATICS (144 marks) – Questions No. 61 to 82 and 89 to 90 consist EIGHT (8) marks each and Questions No. 83 to 88 consist EIGHT (8) marks each for each correct response.
- Candidates will be awarded marks as stated above in instruction No. 5 for correct response of each question $\frac{1}{4}$ (one fourth) marks will be deducted for indicating incorrect response of each question. No deduction from the total score will be made if no response is indicated for an item in the answer sheet.
- Use Blue/Black Ball Point Pen only for writing particulars/markings responses on Side-1 and Side-2 of the Answer Sheet. Use of pencil is strictly prohibited.
- On completion of the test, the candidate must hand over the Answer Sheet to the Invigilator on duty in the Room/Hall. However, the candidates are allowed to take away this Test Booklet with them.

PHYSICS

1. STATEMENT – 1
 For a charged particle moving from point P to point Q, the net work done by an electrostatic field on the particle is independent of the path connected point P to point Q.

STATEMENT – 2
 The net work done by a conservative force on an object moving along a closed loop is zero.

- Statement – 1 is True, Statement – 2 is False.
- Statement – 1 is True, Statement – 2 is True; Statement – 2 is a correct explanation for Statement – 1.
- Statement – 1 is True, Statement – 2 is True; Statement – 2 is not the correct explanation for Statement – 1.
- Statement – 1 is False, Statement – 2 is True.

Key (3)

Sol. Statement–2 is not the correct explanation of statement–1.

2.

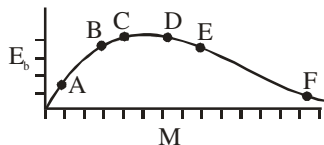

The above is a plot of binding energy per nucleon E_b , against the nuclear mass M ; A, B, C, D, E, F correspond to different nuclei. Consider four reactions :

- $A + B \rightarrow C + \epsilon$
- $C \rightarrow A + B + \epsilon$
- $D + E \rightarrow F + \epsilon$

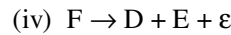

where ϵ is the energy released ? In which reaction is ϵ positive ?

- (i) and (iv)
- (i) and (iii)
- (ii) and (iv)
- (ii) and (iii).

Key. (1)

Sol. Binding energy per nucleon of each product is less than that of each reactants.

3. A p–n junction (4) shown in the figure can act as a rectifier. An alternating current source (V) is connected in the circuit.

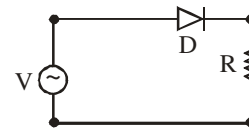

The current (I) in the resistor (R) can be shown by :

-
-
-
-

Key. (3)

Sol. Only +ve current passes through the diode.

4. The logic circuit shown below has the input waveforms 'A' and 'B' as shown. Pick out the correct output waveform.

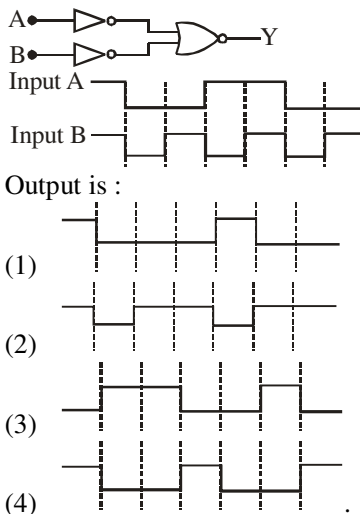

Key. (1)

Sol. Y is true only when both A and B are true. $Y = AB$.

5. If x , v and a denote the displacement, the velocity and the acceleration of a particle executing simple harmonic motion of time period T , then, which of the following does not change with time ?

- (1) $a^2T^2 + 4\pi^2v^2$ (2) aT/x
 (3) $aT + 2\pi v$ (4) aT/v .

Key. (1)

Sol. $x = A \sin \omega t$

$v = A\omega \cos \omega t$

$a = -A\omega^2 \sin \omega t$

Hence, $a^2T^2 + 4\pi^2v^2$

$$= \sin^2 \omega t (-A\omega^2)^2 \left(\frac{2\pi}{\omega}\right)^2 + 4\pi^2 (A\omega)^2 \cos^2 \omega t$$

$$= 4\pi^2 (A\omega)^2 [\sin^2 \omega t + \cos^2 \omega t]$$

which is time independent.

Option (2) however may not be regarded as the correct answer because it is not mentioned that x , the displacement is measured from equilibrium position.

6. In an optics experiment, with the position of the object fixed, a student varies the position of a convex lens and for each position, the screen is adjusted to get a clear image of the object. A graph between the object distance u and the image distance v , from the lens, is plotted using the same scale for the two axes. A straight line passing through the origin and making an angle of 45° with the x -axis meets the experimental curve at P. The coordinates of P will be

- (1) $(2f, 2f)$ (2) $\left(\frac{f}{2}, \frac{f}{2}\right)$
 (3) (f, f) (4) $(4f, 4f)$.

Key. (1)

7. A thin uniform rod of length ℓ and mass m is swinging freely about a horizontal axis passing

through its end. Its maximum angular speed is ω . Its centre of mass rises to a maximum height of

- (1) $\frac{1}{3} \frac{\ell^2 \omega^2}{g}$ (2) $\frac{1}{6} \frac{\ell \omega}{g}$
 (3) $\frac{1}{2} \frac{\ell^2 \omega^2}{g}$ (4) $\frac{1}{6} \frac{\ell^2 \omega^2}{g}$.

Key. (4)

Sol. $\frac{1}{2} \left(\frac{m\ell^2}{3}\right) \omega^2 = mgh$

$$\Rightarrow h = \frac{\omega^2 \ell^2}{6g}$$

8. Let $P(r) = \frac{Q}{\pi R^4} r$ be the charge density

distribution for a solid sphere of radius R and total charge Q . For a point 'p' inside the sphere at distance r_1 from the centre of sphere, the magnitude of electric field is

- (1) 0 (2) $\frac{Q}{4\pi\epsilon_0 r_1^2}$
 (3) $\frac{Qr_1^2}{4\pi\epsilon_0 R^4}$ (4) $\frac{Qr_1^2}{3\pi\epsilon_0 R^4}$.

Key. (3)

Sol. $E = \frac{Q}{4\pi\epsilon_0 r_1^2} \int_{r=0}^{r_1} \frac{4\pi r^3 dr}{\pi R^4}$
 $= \frac{Q}{4\pi\epsilon_0} \frac{r_1^2}{R^4}$.

9. The transition from the state $n = 4$ to $n = 3$ in a hydrogen like atom results in ultraviolet radiation. Infrared radiation will be obtained in the transition from :

- (1) $2 \rightarrow 1$ (2) $3 \rightarrow 2$
 (3) $4 \rightarrow 2$ (4) $5 \rightarrow 4$.

Key. (4)

Sol. Energy of transition is less only in this case.

10. One kg of a diatomic gas is at a pressure of $8 \times 10^4 \text{ N/m}^2$. The density of the gas is 4 kg/m^3 . What is the energy of the gas due to its thermal motion ?

- (1) $3 \times 10^4 \text{ J}$ (2) $5 \times 10^4 \text{ J}$
 (3) $6 \times 10^4 \text{ J}$ (4) $7 \times 10^4 \text{ J}$.

Key. (2)

Sol. $E = \frac{5}{2} nRT$
 $= \frac{5}{2} PV$
 $= \frac{5}{2} \frac{P}{\rho} m$

$$= \frac{5}{2} \times \frac{(8 \times 10^4)(1)}{4} = 5 \times 10^4 \text{ J.}$$

This question contains Statement-1 and Statement-2. Of the four choices given after the statements, choose the one that best describes the two statements.

11. STATEMENT - 1

The temperature dependence of resistance is usually given as $R = R_0 (1 + \alpha \Delta t)$. The resistance of a wire changes from 100Ω to 150Ω when its temperature is increased from 27°C to 227°C . This implies that $\alpha = 2.5 \times 10^{-3} / ^\circ\text{C}$.

STATEMENT - 2

$R = R_0 (1 + \alpha \Delta t)$ is valid only when the change in the temperature ΔT is small and $\Delta R = (R - R_0) \ll R_0$.

- (1) Statement - 1 is True, Statement - 2 is False.
- (2) Statement - 1 is True, Statement - 2 is True; Statement - 2 is a correct explanation for Statement - 1.
- (3) Statement - 1 is True, Statement - 2 is True; Statement - 2 is not the correct explanation for Statement - 1.
- (4) Statement - 1 is False, Statement - 2 is True.

Key (4)

Sol. R_0 is the resistance at 0°C .

Directions : Question numbers 12 and 13 are based on the following paragraph.

A current loop ABCD is held fixed on the plane of the paper as shown in the figure. The arcs BC (radius = b) and DA (radius = a) of the loop are joined by two straight wires AB and CD. A steady current I is flowing in the loop. Angle made by AB and CD at the origin O is 30° . Another straight thin wire with steady current I_1 flowing out of the plane of the paper is kept at the origin.

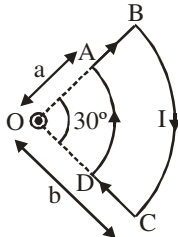

12. The magnitude of the magnetic field (2) due to the loop ABCD at the origin (O) is

- (1) zero
- (2) $\frac{\mu_0 I (b - a)}{24ab}$
- (3) $\frac{\mu_0 I}{4\pi} \left[\frac{b - a}{ab} \right]$

$$(4) \frac{\mu_0 I}{4\pi} \left[2(b - a) + \frac{\pi}{3}(a + b) \right].$$

Key. (2)

Sol. $B = \frac{1}{12}$ of $\frac{\mu_0 I}{2} \left(\frac{1}{a} - \frac{1}{b} \right)$
 $= \frac{\mu_0 I (b - a)}{24ab}$.

13. Due to the presence of the current I_1 at the origin :

- (1) the forces on AB and DC are zero
- (2) the forces on AD and BC are zero
- (3) the magnitude of the net force on the loop

is given by $\frac{I_1 I}{4\pi} \mu_0 \left[2(b - a) + \frac{\pi}{3}(a + b) \right]$

(4) the magnitude of the net force on the loop is given by $\frac{\mu_0 I I_1}{24ab} (b - a)$.

Key. (2)

Sol. $\vec{F} = I(\vec{\ell} \times \vec{B}) = 0$.

14. A mixture of light, consisting of wavelength 590 nm and an unknown wavelength, illuminates Young's double slit and gives rise to two overlapping interference patterns on the screen. The central maximum of both lights coincide. Further, it is observed that the third bright fringe of known light coincides with the 4th bright fringe of the unknown light. From this data, the wavelength of the unknown light is :

- (1) 393.4 nm (2) 885.0 nm
- (3) 442.5 nm (4) 776.8 nm.

Key. (3)

Sol. Fringe width = $\frac{\lambda d}{D}$

$\therefore \lambda_{\text{unknown}} = \frac{3}{4} \times 590 \text{ nm}$
 $= 442.5 \text{ nm}.$

15. Two points P and Q are maintained at the potentials of 10V and -4V, respectively. The work done in moving 100 electrons from P to Q is

- (1) $-9.60 \times 10^{-17} \text{ J}$ (2) $9.60 \times 10^{-17} \text{ J}$
- (3) $-2.24 \times 10^{-16} \text{ J}$ (4) $2.24 \times 10^{-16} \text{ J}.$

Key. (4)

Sol. $W = 100 \times 1.6 \times 10^{-19} \times 14$
 $= 2.24 \times 10^{-16} \text{ J}.$

16. The surface of a metal is illuminated with the light of 400 nm. The kinetic energy of the ejected photoelectrons was found to be 1.68 eV. The work function of the metal is : ($hc = 1240 \text{ eV.nm}$)

- (1) 3.09 eV (2) 1.41 eV
- (3) 1.51 eV (4) 1.68 eV.

Key. (2)

Sol. $\frac{hc}{\lambda} = \phi + (KE)_{\max}$
 $\Rightarrow \frac{1240}{400} = \phi + 1.68$
 $\Rightarrow \phi = 1.41 \text{ eV}$

17. A particle has an initial velocity of $3\hat{i} + 4\hat{j}$ and an acceleration of $0.4\hat{i} + 0.3\hat{j}$. It speed after 10 s is :

- (1) 10 units (2) $7\sqrt{2}$ units
 (3) 7 units (4) 8.5 units.

Key. (2)

Sol. $\vec{V} = \vec{u} + \vec{at}$
 $\vec{V} = (3\hat{i} + 4\hat{j}) + 10(0.4\hat{i} + 0.3\hat{j})$
 $\vec{V} = 7\hat{i} + 7\hat{j}$
 $\Rightarrow |\vec{V}| = 7\sqrt{2}$

18. A motor cycle starts from rest and accelerates along a straight path at 2 m/s^2 . At the straight point of the motor cycle there is a stationary electric siren. How far has the motor cycle gone when the driver hears the frequency of the siren at 94% of its value when the motor cycle was at rest ?

- (Speed of sound = 330 ms^{-1})
 (1) 49 m (2) 98 m
 (3) 147 m (4) 196 m.

Key. (2)

18. $V = \sqrt{2aS} = \sqrt{4S}$
 Also, $94 = 100 \left(\frac{330 - V}{330} \right)$
 $\Rightarrow \frac{33 \times 6}{10} = \sqrt{4S}$
 $\Rightarrow S = 98 \text{ m}$

19. Consider a rubber ball freely falling from a height $h = 4.9 \text{ m}$ onto a horizontal elastic plate. Assume that the duration of collision is negligible and the collision with the plate is totally elastic.

Then the velocity as a function of time and the height as a function of time will be :

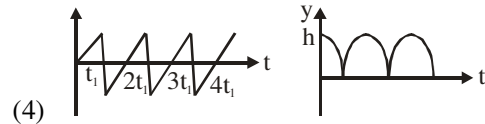
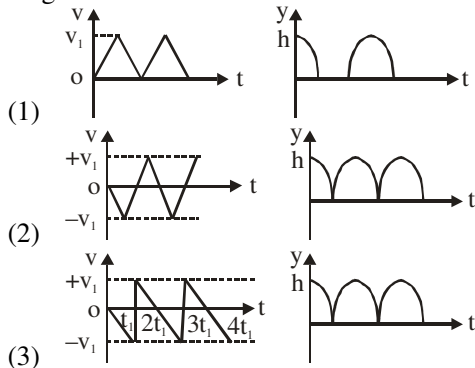

(4)

Key. (3)

Sol. When ball strikes the surface its velocity will be reversed so correct option is (3).

20. A charge Q is placed at each of the opposite corners of a square. A charge q is placed at each of the other two corners. If the net electrical force on Q is zero, then Q/q equals:

- (1) $-2\sqrt{2}$ (2) -1
 (3) 1 (4) $-\frac{1}{\sqrt{2}}$.

Key. (1)

Sol. $\frac{KQ}{2a^2} = \sqrt{2} \frac{Kq}{a^2}$
 $\Rightarrow \left| \frac{Q}{q} \right| = 2\sqrt{2}$
 So, $\frac{Q}{q} = -2\sqrt{2}$

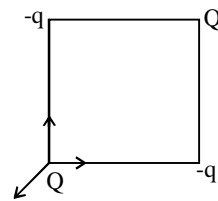

21. A long metallic bar is carrying heat from one of its ends to the other end under steady-state. The variation of temperature θ along the length x of the bar from its hot end is best described by which of the following figures ?

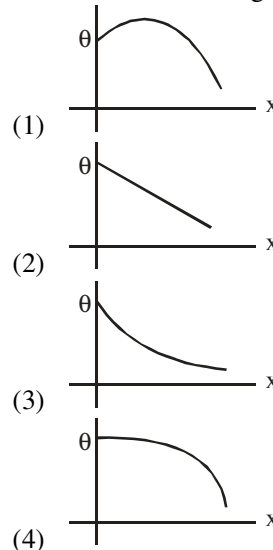

(4)

Key. (2)

Sol. $\frac{T_1 - T_2}{L} = \frac{T_1 - T_x}{x}$
 $\frac{L}{KA} = \frac{x}{KA}$

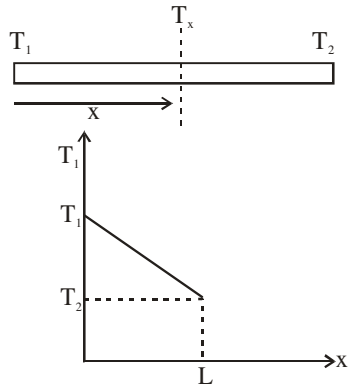

$$\Rightarrow T_x = T_1 - \left(\frac{T_1 - T_2}{L}\right)x$$

22. A transparent solid cylindrical rod has a refractive index of $\frac{2}{\sqrt{3}}$. It is surrounded by air. A light ray is incident at the mid-point of one end of the rod as shown in the figure.



The incident angle θ for which the light ray grazes along the wall of the rod is :

- (1) $\sin^{-1}\left(\frac{1}{2}\right)$ (2) $\sin^{-1}\left(\frac{\sqrt{3}}{2}\right)$
 (3) $\sin^{-1}\left(\frac{2}{\sqrt{3}}\right)$ (4) $\sin^{-1}\left(\frac{1}{\sqrt{3}}\right)$.

Key. (4)

Sol. $1 \times \sin 90 = \frac{2}{\sqrt{3}} \sin(90 - \alpha)$

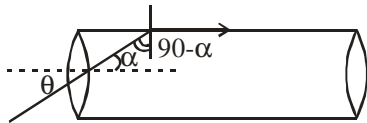

$$\Rightarrow \cos \alpha = \frac{\sqrt{3}}{2}$$

So $\sin \alpha = \sqrt{1 - \frac{3}{4}} = \frac{1}{2}$

Now, $1 \times \sin \theta = \frac{2}{\sqrt{3}} \sin \alpha$

$$= \frac{2}{\sqrt{3}} \times \frac{1}{2} = \frac{1}{\sqrt{3}}$$

$$\Rightarrow \theta = \sin^{-1} \frac{1}{\sqrt{3}}$$

23. Three sound waves of equal amplitudes have frequencies $(\nu - 1)$, ν , $(\nu + 1)$. They superpose to give beats. The number of beats produced per second will be
- (1) 4 (2) 3
 (3) 2 (4) 1.

Key. (3)

Sol. $p_1 = p_0 \sin 2\pi(x - 1)t$
 $p_2 = p_0 \sin 2\pi(x)t$
 $p_3 = p_0 \sin 2\pi(x + 1)t$
 $p = p_1 + p_3 + p_2$

$$= p_0 \sin 2\pi(x - 1)t + p_0 \sin 2\pi(x + 1)t + p_0 \sin 2\pi(x)t$$

$$= 2p_0 \sin 2\pi(x)t \cos 2\pi t + p_0 \sin 2\pi(x)t$$

$$= p_0 \sin 2\pi(x)t [2 \cos 2\pi t + 1]$$

$$\Rightarrow f_{\text{beat}} = 2.$$

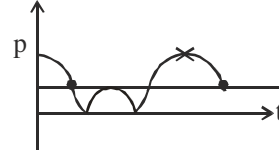

24. The height at which the acceleration due to gravity becomes $\frac{g}{9}$ (where g = the acceleration due to gravity on the surface of the earth) in terms of R , the radius of the earth, is :

- (1) $2R$ (2) $\frac{R}{\sqrt{2}}$
 (3) $R/2$ (4) $\sqrt{2}R$.

Key. (1)

Sol. $\frac{GM}{9R^2} = \frac{GM}{(R + h)^2}$
 $\Rightarrow 3R = R + h$
 $\Rightarrow h = 2R$

25. Two wires are made of the same material and have the same volume. However wire 1 has cross-section area A and wire 2 has cross-sectional area $3A$. If the length of wire 1 increases by Δx on applying force F , how much force is needed to stretch wire 2 by the same amount ?

- (1) F (2) $4F$
 (3) $6F$ (4) $9F$.

Key. (4)

Sol. $\ell_1 = 3\ell_2$
 $Y = \frac{F}{A} \times \frac{\ell_1}{\Delta x} \dots(i)$
 $Y = \frac{F'}{3A} \times \frac{\ell_1/3}{\Delta x} \dots(ii)$
 $\frac{F}{A} \times \frac{\ell_1}{\Delta x} = \frac{F'}{3A} \times \frac{\ell_1}{3\Delta x}$
 $F' = 9F$

26. In an experiment the angles are required to be measured using an instrument. 29 divisions of the main scale exactly coincide with the 30 divisions of the vernier scale. If the smallest division of the main scale is half-a-degree

(= 0.5°), then the least count of the instrument is:

- (1) one minute (2) half minute
(3) one degree (4) half degree.

Key. (1)

Sol. $1 \text{ VSD} = \frac{29}{30} \text{ MSD}$

L.C. = 1 MSD – 1 VSD

= $\frac{1}{30} \text{ MSD}$

= $\frac{1}{30} \times 0.5 = \frac{1}{60} = \text{one minute}$

27.

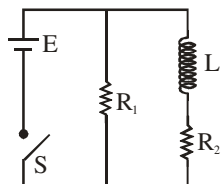

An inductor of inductance $L = 400 \text{ mH}$ and resistors of resistances $R_1 = 2 \Omega$ and $R_2 = 2 \Omega$ are connected to a battery of emf 12 V as shown in the figure. The internal resistance of the battery is negligible. The switch S is closed at $t = 0$. The potential drop across L as a function of time is :

- (1) $6 e^{-5t} \text{ V}$ (2) $\frac{12}{t} e^{-3t} \text{ V}$
(3) $6 \left(1 - e^{-\frac{t}{0.2}}\right) \text{ V}$ (4) $12 e^{-5t} \text{ V}$.

Key. (4)

Sol. $e_L = E e^{-\frac{tR_2}{L}}$

$e_L = 12 e^{-\frac{2}{4}t}$

$e_L = 12 e^{-5t}$.

Directions : Question numbers 28, 29 and 30 are based on the following paragraph.

Two moles of helium gas are taken over the cycle ABCDA, as shown in the P–T diagram.

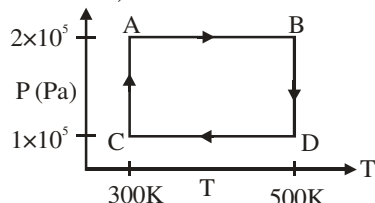

28. Assuming the gas to be ideal the work done on the gas in taking it from A to B is :

- (1) 200 R (2) 300 R
(3) 400 R (4) 500 R.

Key. (3)

Sol. $W_{AB} = nR(T_f - T_i)$
 $= 2 \times R(500 - 300)$

= 400 R

29. The work done on the gas is taking it from D to A is

- (1) -414 R (2) +414 R
(3) -690 R (4) +690 R.

Key. (1)

Sol. $W_{DA} = nRT \ln \frac{P_i}{P_f} = 2 \times R \times 300 \ln \frac{1}{2}$

= -414 R

30. The net work done on the gas in the cycle ABCDA is

- (1) zero (2) 276 R
(3) 1076 R (4) 1904 R.

Key. (2)

30. $W_{ABCD} = W_{AB} + W_{BC} + W_{CD} + W_{DA}$

$W_{BC} = 2 \times R \times 500 \ln 2$
 $= 690 \text{ R}$

$W_{CD} = 2 \times R \times (300 - 500)$
 $= -400 \text{ R}$

$W_{ABCD} = 400 \text{ R} + 690 \text{ R} + (-400 \text{ R}) - 414 \text{ R}$
 $= 276 \text{ R}$.

CHEMISTRY

31. Knowing that the Chemistry of lanthanoids (Ln) is dominated by its +3 oxidation state, which of the following statements is incorrect?

- (1) Because of the large size of the Ln (III) ions the bonding in its compounds is predominantly ionic in character.
(2) The ionic sizes of Ln (III) decrease in general with increasing atomic number.
(3) Ln (III) compounds are generally colourless
(4) Ln (III) hydroxides are mainly basic in character.

Key. (3)

Sol. Most of the Ln(III) compounds are coloured due to f – f transition.

32. A liquid was mixed with ethanol and a drop of concentrated H_2SO_4 was added. A compound with a fruity smell was formed. The liquid was:

- (1) CH_3OH (2) HCHO
(3) CH_3COCH_3 (4) CH_3COOH

Key. (4)

Sol. Fruity smell is evolved due to formation of ester.

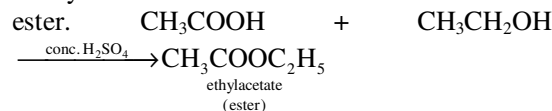

33. Arrange the carbanions, $(\text{CH}_3)_3\bar{\text{C}}$, $\bar{\text{C}}\text{Cl}_3$, $(\text{CH}_3)_2\bar{\text{C}}\text{H}$, $\text{C}_6\text{H}_5\bar{\text{C}}\text{H}_2$, in order of their decreasing stability:

- (1) $C_6H_5\bar{C}H_2 > \bar{C}Cl_3 > (CH_3)_3\bar{C} > (CH_3)_2\bar{C}H$
 (2) $(CH_3)_2\bar{C}H > \bar{C}Cl_3 > C_6H_5\bar{C}H_2 > (CH_3)_3\bar{C}$
 (3) $\bar{C}Cl_3 > C_6H_5\bar{C}H_2 > (CH_3)_2\bar{C}H > (CH_3)_3\bar{C}$
 (4) $(CH_3)_3\bar{C} > (CH_3)_2\bar{C}H > C_6H_5\bar{C}H_2 > \bar{C}Cl_3$

Key. (3)

Sol. Due to the -I effect of three chlorine atoms and due to $p\pi - d\pi$ bonding $\bar{C}Cl_3$ is extra stable.

Carbanion follow stability order.

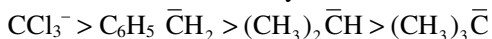

34. The alkene that exhibits geometrical isomerism is:

- (1) propene (2) 2-methyl propene
 (3) 2-butene (4) 2-methyl-2-butene

Key. (3)

Sol. 2-butene may exist as

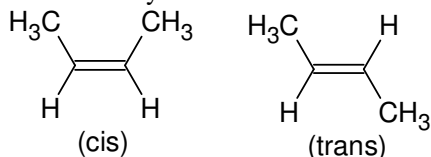

Due to restricted rotation around double bond it exhibits geometric isomerism.

35. In which of the following arrangements, the sequence is not strictly according to the property written against it?

- (1) $CO_2 > SiO_2 < SnO_2 < PbO_2$: increasing oxidizing power
 (2) $HF < HCl < HBr < HI$: increasing acid strength
 (3) $NH_3 < PH_3 < AsH_3 < SbH_3$: increasing basic strength
 (4) $B < C < O < N$: increasing first ionization enthalpy

Key. (3)

Sol. As the size of the central non-metal increasing appreciably, the basicity of hydride decreases.

36. The major product obtained on interaction of phenol with sodium hydroxide and carbon dioxide is:

- (1) benzoic acid (2) salicylaldehyde
 (3) salicylic acid (4) phthalic acid

Key. (3)

Sol. According to Kolbe's reaction

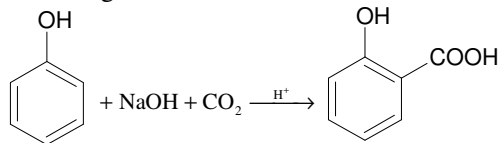

37. Which of the following statement is incorrect regarding physisorptions?

- (1) It occurs because of van der Waal's forces.

(2) More easily liquefiable gases are adsorbed readily

(3) Under high pressure it results into multi molecular layer on adsorbent surface

(4) Enthalpy of adsorption ($\Delta H_{\text{adsorption}}$) is low and positive.

Key. (4)

Sol. Enthalpy of adsorption in physisorption is negative

$$\Delta G = \Delta H - T\Delta S$$

As the entropy decreases ($\Delta S = -ve$) the ΔH must be negative having a high magnitude. Therefore, the spontaneous adsorption will have negative enthalpy change.

38. Which of the following on heating with aqueous KOH, produces acetaldehyde?

- (1) CH_3COCl (2) CH_3CH_2Cl
 (3) CH_2ClCH_2Cl (4) CH_3CHCl_2

Key. (4)

Sol.

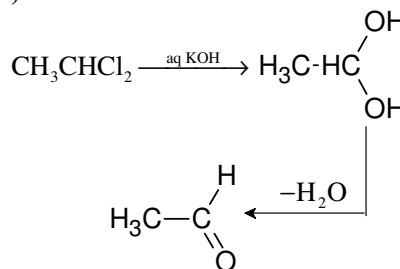

39. In an atom, an electron is moving with a speed of 600 m/s with an accuracy of 0.005%. certainty with which the position of the electron can be located is ($h = 6.6 \times 10^{-34} \text{ kg m}^2 \text{ s}^{-1}$, mass of electron $e_m = 9.1 \times 10^{-31} \text{ kg}$):

- (1) $1.52 \times 10^{-4} \text{ m}$ (2) $5.01 \times 10^{-3} \text{ m}$
 (3) $1.92 \times 10^{-3} \text{ m}$ (4) $3.84 \times 10^{-3} \text{ m}$

Key. (3)

Sol. $\Delta v = . = 9.1 \times 10^{-31} \text{ kg}$

$$\Delta x = ?$$

$$\Delta x \times m \Delta v \geq \frac{h}{4\pi}$$

$$\Delta x \geq \frac{h}{4m\Delta v\pi}$$

$$\geq \frac{6.6 \times 10^{-34}}{4 \times 9.1 \times 10^{-31} \times 0.03 \times 3.14}$$

$$\geq 1.9248 \times 10^{-3}$$

40. In a fuel cell methanol is used as fuel and oxygen gas is used as an oxidizer. The reaction is

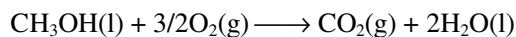

At 298 K standard Gibb's energies of formation for $CH_3OH(l)$, $H_2O(l)$ and $CO_2(g)$ are -166.2 , -237.2 and $-394.4 \text{ kJ mol}^{-1}$ respectively. If

standard enthalpy of combustion of methanol is -726 kJ mol^{-1} , efficiency of the fuel cell will be:

- (1) 80% (b) 87%
(3) 90% (4) 97%

Key. (4)

Sol. $2(-237.2) - 394.4 + 166.2$
 $= -474.4 - 394.4 + 166.2$

$$\frac{702.6}{726} \times 100 = 96.77$$

41. Two liquids X and Y form an ideal solution. At 300 K, vapour pressure of the solution containing 1 mol of X and 3 mol of Y is 550 mm Hg. At the same temperature, if 1 mol of Y is further added to this solution, vapour pressure of the solution increases by 10 mm Hg. Vapour pressure (in mmHg) of X and Y in their pure states will be respectively:

- (1) 200 and 300 (2) 300 and 400
(3) 400 and 600 (4) 500 and 600

Key. (3)

Sol. $0.25P_A^0 + 0.75P_B^0 = 550 \text{ mm}$
 $0.20P_A^0 + 0.80P_B^0 = 650 \text{ mm}$

$$P_X^0 + 3P_Y^0 = 2200$$

$$P_X^0 + 4P_Y^0 = 2800$$

$$P_Y^0 = 600 \text{ mm}$$

$$P_X^0 = 400 \text{ mm}$$

42. The half life period of a first order chemical reaction is 6.93 minutes. The time required for the completion of 99% of the chemical reaction will be ($\log 2 = 0.301$)

- (1) 230.3 minutes (2) 23.03 minute
(3) 46.06 minutes (4) 460.6 minutes

Key. (3)

Sol. $K = \frac{0.693}{6.93} = 10^{-1} \text{ min}^{-1}$

$$10^{-1} = \frac{2.303}{t} \log \frac{100}{1}$$

$$t = \frac{2.303 \times 2}{10^{-1}} = 46.06 \text{ min}$$

43. Given:

$E_{\text{Fe}^{3+}/\text{Fe}}^0 = -0.036 \text{ V}$, $E_{\text{Fe}^{2+}/\text{Fe}}^0 = -0.439 \text{ V}$. The value of standard electrode potential for the change,

$\text{Fe}^{3+}_{(\text{aq})} + e^- \rightarrow \text{Fe}^{2+}_{(\text{aq})}$ will be:

- (1) -0.072 V (2) 0.385 V
(3) 0.770 V (4) -0.270 V

Key. (3)

Sol. $\text{Fe}^{3+} + 3e^- \rightarrow \text{Fe}$, $E^0 = -0.036 \text{ V}$

$\text{Fe}^{2+} + 2e^- \rightarrow \text{Fe}$, $E^0 = -0.439 \text{ V}$

$\text{Fe}^{3+} + e^- \rightarrow \text{Fe}^{2+}$,

$$E^0 = \frac{3(-0.036) - 2(-0.439)}{1}$$

$$= 0.770 \text{ V}$$

44. On the basis of the following thermochemical data: ($\Delta_f G^0 \text{H}^+_{(\text{aq})} = 0$)

$\text{H}_2\text{O}(\text{l}) \longrightarrow \text{H}^+(\text{aq}) + \text{OH}^-(\text{aq}); \Delta H = 57.32 \text{ kJ}$

$\text{H}_2(\text{g}) + \frac{1}{2} \text{O}_2(\text{g}) \longrightarrow \text{H}_2\text{O}(\text{l}); \Delta H = -286.20 \text{ kJ}$

The value of enthalpy of formation of OH^- ion at 25°C is:

- (1) -22.88 kJ (2) -228.88 kJ
(3) $+228.88 \text{ kJ}$ (4) -343.52 kJ

Key. (2)

Sol. $57.32 = \Delta H_f(\text{OH}_{(\text{aq})}) + \Delta H_f(\text{H}^+(\text{aq})) - \Delta H_f(\text{H}_2\text{O}(\text{l}))$

$$\Delta H_f(\text{OH}_{(\text{aq})}) = 57.32 + (-286.20)$$

$$286.20 - 57.32 = -228.88$$

45. Copper crystallizes in fcc with a unit cell length of 361 pm. What is the radius of copper atom?

- (1) 109 pm (2) 127 pm
(3) 157 pm (4) 181 pm

Key. (2)

Sol. For FCC

$$\sqrt{2} a = 4r$$

$$\therefore r = \frac{\sqrt{2} \times 361}{4} = 127 \text{ pm}$$

46. Which of the following has an optical isomer?

- (1) $[\text{Co}(\text{NH}_3)_3\text{Cl}]^+$
(2) $[\text{Co}(\text{en})(\text{NH}_3)_2]^{2+}$
(3) $[\text{Co}(\text{H}_2\text{O})_4(\text{en})]^{3+}$
(4) $[\text{Co}(\text{en})_2(\text{NH}_3)_2]^{3+}$

Key. (4)

Sol.

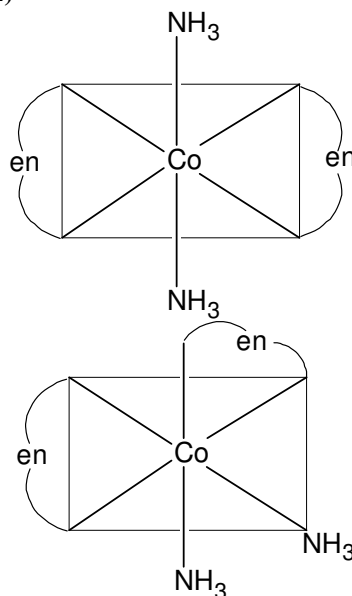

47. Solid $\text{Ba}(\text{NO}_3)_2$ is gradually dissolved in a $1.0 \times 10^{-4} \text{ M}$ Na_2CO_3 solution. At what concentration of Ba^{2+} will a precipitate begin to form? (K_{sp} for $\text{BaCO}_3 = 5.1 \times 10^{-9}$):

- (1) $4.1 \times 10^{-5} \text{ M}$ (2) $5.1 \times 10^{-5} \text{ M}$
 (3) $8.1 \times 10^{-8} \text{ M}$ (4) $8.1 \times 10^{-7} \text{ M}$

Key. (2)

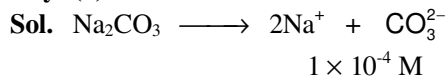

$K_{\text{SP}} = [\text{Ba}^{2+}] [\text{CO}_3^{2-}]$

$5.1 \times 10^{-9} = [\text{Ba}^{2+}] [1 \times 10^{-4}]$

$[\text{Ba}^{2+}] = \frac{5.1 \times 10^{-9}}{1 \times 10^{-4}}$
 $= 5.1 \times 10^{-5} \text{ M}$

48. Which one of the following reactions of Xenon compounds is not feasible?

- (1) $\text{XeO}_3 + 6\text{HF} \rightarrow \text{XeF}_6 + 3\text{H}_2\text{O}$
 (2) $3\text{XeF}_4 + 6\text{H}_2\text{O} \rightarrow 2\text{Xe} + \text{XeO}_3 + 12\text{HF} + 1.5\text{O}_2$
 (3) $2\text{XeF}_2 + 2\text{H}_2\text{O} \rightarrow 2\text{Xe} + 4\text{HF} + \text{O}_2$
 (4) $\text{XeF}_6 + \text{RbF} \rightarrow \text{Rb}[\text{XeF}_7]$

Key. (1)

49. Using MO theory predict which of the following species has the shortest bond length?

- (1) O_2^{2+} (2) O_2^+
 (3) O_2^- (4) O_2^{2-}

Key. (1)

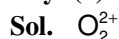

$\text{B.O.} = \frac{1}{2}[\text{N}_6 - \text{Na}]$

$= \frac{1}{2}[10 - 4]$

$\text{B.O.} = 3$

So bond length is shortest

50. In context with the transition elements, which of the following statements is incorrect?

- (1) In addition to the normal oxidation states, the zero oxidation state is also shown by these elements in complexes.
 (2) In the highest oxidation states, the transition metal show basic character and form cationic complexes.
 (3) In the highest oxidation states of the first five transition element (Sc to Mn), all the 4s and 3d electrons are used for bonding.
 (4) Once the d^5 configuration is exceeded, the tendency to involve all the 3d electrons in bonding decreases.

Key. (2)

Sol. In highest oxidation states transition metals form anionic complexes rather than that of cationic complexes.

51. Calculate the wavelength (in nanometer) associated with a proton moving at $1.0 \times 10^3 \text{ ms}^{-1}$

(Mass of proton = $1.67 \times 10^{-27} \text{ kg}$ and $h = 6.63 \times 10^{-34} \text{ Js}$):

- (1) 0.032 nm (2) 0.40 nm
 (3) 2.5 nm (4) 14.0 nm

Key. (2)

Sol. $\lambda = \frac{h}{mv} = \frac{6.63 \times 10^{-34}}{1.67 \times 10^{-27} \times 1 \times 10^3}$
 $= \frac{6.63 \times 10^{-34}}{1.67 \times 10^{-24}}$
 $= 0.40 \times 10^{-9} \text{ m}$
 $= 0.40 \text{ nm}$

52. A binary liquid solution is prepared by mixing n-heptane and ethanol. Which one of the following statement is correct regarding the behaviour of the solution?

- (1) The solution formed is an ideal solution
 (2) The solution is non-ideal, showing +ve deviation from Raoult's Law
 (3) The solution is non-ideal, showing -ve deviation from Raoult's Law
 (4) n-heptane shows +ve deviation while ethanol shows -ve deviation from Raoult's Law.

Key. (2)

Sol. On mixing n-heptane and ethanol; strong interactions are replaced by weak interaction and hence it kes non-ideal solution with positive deviation.

53. The number of stereoisomers possible for a compound of the molecular formula $\text{CH}_3 - \text{CH} = \text{CH} - \text{CH}(\text{OH}) - \text{Me}$ is:

- (1) 3 (2) 2
 (3) 4 (4) 6

Key. (3)

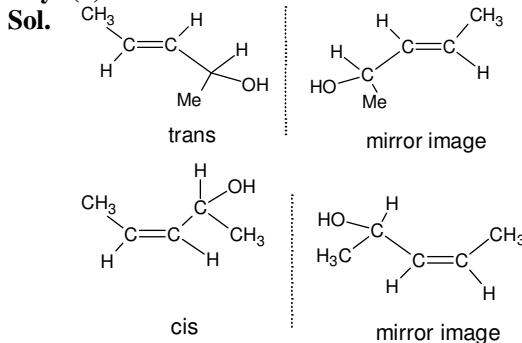

54. The IUPAC name of neopentane is:

- (1) 2 - methylbutane

- (2) 2, 2 - dimethylpropane
 (3) 2 - methylpropane
 (4) 2, 2 - dimethylbutane

Key. (2)

Sol.

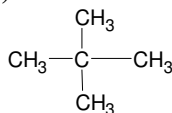

2, 2 dimethyl propane

55. The set representing the correct order of ionic radius is:

- (1) $\text{Li}^+ > \text{Be}^{2+} > \text{Na}^+ > \text{Mg}^{2+}$
 (2) $\text{Na}^+ > \text{Li}^+ > \text{Mg}^{2+} > \text{Be}^{2+}$
 (3) $\text{Li}^+ > \text{Na}^+ > \text{Mg}^{2+} > \text{Be}^{2+}$
 (4) $\text{Mg}^{2+} > \text{Be}^{2+} > \text{Li}^+ > \text{Na}^+$

Key. (2)

Sol.

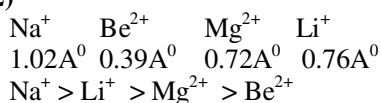

56. The two functional groups present in a typical carbohydrate are:

- (1) —OH and —COOH
 (2) —CHO and —COOH
 (3) $>\text{C}=\text{O}$ and —OH
 (4) —OH and —CHO

Key. (3)

Sol. Carbohydrates are primarily hydroxyl carbonyl compound hence $>\text{C}=\text{O}$ and —OH are present.

57. The bond dissociation energy of B - F in BF_3 is 646 kJ mol^{-1} whereas that of C - F in CF_4 is 515 kJ mol^{-1} . The correct reason for higher B-F bond dissociation energy as compared to that of C - F is:

- (1) smaller size of B - atom as compared to that of C - atom
 (2) stronger σ bond between B and F in BF_3 as compared to that between C and F in CF_4
 (3) significant $p\pi - p\pi$ interaction between B and F in BF_3 whereas there is no possibility of such interaction between C and F in CF_4
 (4) lower degree of $p\pi - p\pi$ interaction between B and F in BF_3 than that between C and F in CF_4

Key. (3)

Sol.

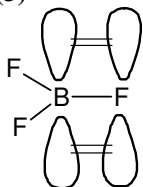

B has vacant available p orbital and hence it involves $p\pi - p\pi$ back bonding which is not possible in CF_4 as C does not have vacant orbital.

58. In Cannizzaro reaction given below

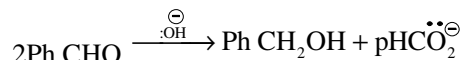

The slowest step is:

- (1) the attack of $:\text{OH}^-$ at the carboxyl group
 (2) the transfer of hydride to the carbonyl group
 (3) the abstraction of proton from the carboxylic group
 (4) the deprotonation of pHCH_2OH

Key. (2)

Sol.

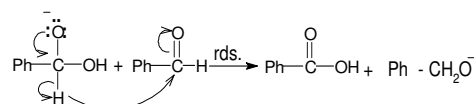
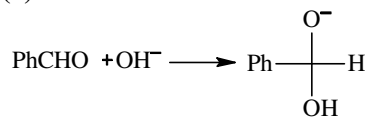

Proton transfer is rate determining step

59. Which of the following pairs represents linkage isomers?

- (1) $[\text{Cu}(\text{NH}_3)_4] [\text{PtCl}_4]$ and $[\text{Pt}(\text{NH}_3)_4] [\text{CuCl}_4]$
 (2) $[\text{Pd}(\text{PPh}_3)_2 (\text{NCS})_2]$ and $[\text{Pd}(\text{PPh}_3)_2 (\text{SCN})_2]$
 (3) $[\text{CO}(\text{NH}_3)_5 \text{NO}_3] \text{SO}_4$ and $[\text{CO}(\text{NH}_3)_5 \text{SO}_4] \text{NO}_3$
 (4) $[\text{PtCl}_2 (\text{NH}_3)_4] \text{Br}_2$ and $[\text{PtBr}_2 (\text{NH}_3)_4] \text{Cl}_2$

Key. (2)

Sol. Linkage isomerism is shown by ambident ligand like NCS and SCN

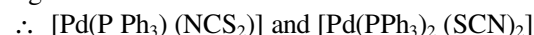

60. Buna-N synthetic rubber is a copolymer of:

- (1) $\text{H}_2\text{C}=\text{CH}-\overset{\text{Cl}}{\underset{|}{\text{C}}}=\text{CH}_2$ and $\text{H}_2\text{C}=\text{CH}-\text{CH}=\text{CH}_2$
 (2) $\text{H}_2\text{C}=\text{CH}-\text{CH}=\text{CH}_2$ and $\text{H}_3\text{C}-\text{CH}=\text{CH}_2$
 (3) $\text{H}_2\text{C}=\text{CH}-\text{CN}$ and $\text{H}_2\text{C}=\text{CH}-\text{CH}=\text{CH}_2$
 (4) $\text{H}_2\text{C}=\text{CH}-\text{CN}$ and $\text{H}_2\text{C}=\text{CH}-\overset{\text{Cl}}{\underset{|}{\text{C}}}=\text{CH}_2$

Key. (3)

Sol. $n \text{CH}_2=\text{CH}-\text{CH}=\text{CH} + \text{HCH}=\text{CH}-\text{CN}$

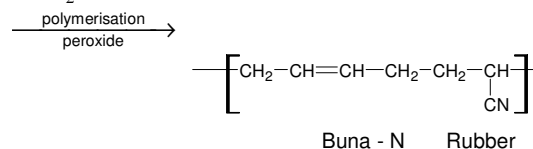

MATHEMATICS

61. Let a, b, c be such that $b(a + c) \neq 0$. If

$$\begin{vmatrix} a & a+1 & a-1 \\ -b & b+1 & b-1 \\ c & c-1 & c+1 \end{vmatrix} + \begin{vmatrix} a+1 & b+1 & c-1 \\ a-1 & b-1 & c+1 \\ (-1)^{n+2}a & (-1)^{n+1}b & (-1)^n c \end{vmatrix} = 0,$$

then the value of n is

- (1) zero (2) any even integer
(3) any odd integer (4) any integer

Key (3)

Sol.:
$$\begin{vmatrix} a & -b & c \\ a+1 & b+1 & c-1 \\ a+1 & b-1 & c+1 \end{vmatrix} + \begin{vmatrix} (-1)^{n+2}a & (-1)^{n+1}b & (-1)^n c \\ a+1 & b+1 & c-1 \\ a-1 & b-1 & c+1 \end{vmatrix} = \begin{vmatrix} a(1+(-1)^n) & (-b)(1+(-1)^n) & c(1+(-1)^n) \\ a+1 & b+1 & c-1 \\ a-1 & b-1 & c+1 \end{vmatrix} = 0$$

62. If the mean deviation of the numbers 1, 1 + d, 1 + 2d, ..., 1 + 100d from their mean is 255, then the d is equal to

- (1) 10.0 (2) 20.0
(3) 10.1 (4) 20.2

Key (3)

Sol.:
$$\frac{|x - \bar{x}|}{n} = 255$$

$$\bar{x} = \frac{1+1+d+1+2d+\dots+1+100d}{101}$$

$$= \frac{101+d\left(\frac{100 \times 101}{2}\right)}{101}$$

$$= 1 + \frac{50 \times 101d}{101} = 1 + 50d$$

$$|x - \bar{x}| = 255 \times 101$$

$$2d\left(\frac{50 \times 51}{2}\right) = 255 \times 101$$

$$d = \frac{255 \times 101}{50 \times 51} = 10.1$$

63. If the roots of the equation $bx^2 + cx + a = 0$ be imaginary, then for all real values of x, the expression $3b^2x^2 + 6bcx + 2c^2$ is

- (1) greater than 4ab (2) less than 4ab
(3) greater than -4ab (4) less than -4ab

Key (3)

Sol.: As, $bx^2 + cx + a = 0$ has imaginary roots
So, $c^2 < 4ab$
Now, $3b^2x^2 + 6bcx + 2c^2$
 $= 3(bx + c)^2 - c^2 \geq -c^2 \geq -4ab$

64. Let A and B denote the statements

- A: $\cos \alpha + \cos \beta + \cos \gamma = 0$
B: $\sin \alpha + \sin \beta + \sin \gamma = 0$

If $\cos(\beta - \gamma) + \cos(\gamma - \alpha) + \cos(\alpha - \beta) = -3/2$, then

- (1) A is true and B is false
(2) A is false and B is true
(3) both A and B are true
(4) both A and B are false

Key (3)

Sol.: $\cos(\beta - \gamma) + \cos(\gamma - \alpha) + \cos(\alpha - \beta) = -3/2$
 $\Rightarrow 2\cos(\beta - \gamma) + 2\cos(\gamma - \alpha) + 2\cos(\alpha - \beta) = -3$
 $\Rightarrow \Sigma(\cos \beta \cos \gamma + 2\Sin \alpha \sin \beta + 3) = 0$
 $\Rightarrow (\cos \alpha + \cos \beta + \cos \gamma)^2 + (\sin \alpha + \sin \beta + \sin \gamma)^2 = 0$
 $\Rightarrow \cos \alpha + \cos \beta + \cos \gamma = 0$
 $\sin \alpha + \sin \beta + \sin \gamma = 0$

65. The lines $p(p^2 + 1)x - y + q = 0$ and $(p^2 + 1)^2x + (p^2 + 1)y + 2q = 0$ are perpendicular to a common line for

- (1) no value of p
(2) exactly one value of p
(3) exactly two values of p
(4) more than two values of p

Key (2)

Sol.: $p(p^2 + 1) = \frac{-(p^2 + 1)^2}{p^2 + 1}$
 $y = q$
 $x + y + 2q = 0$
 $\Rightarrow p = -1.$

66. If A, B and C are three sets such that $A \cap B = A \cap C$ and $A \cup B = A \cup C$, then

- (1) A = B (2) A = C
(3) B = C (4) $A \cap B = \phi$

Key (3)

Sol.: $A \cup B = A \cup C$
 $\Rightarrow n(A \cup B) = n(A \cup C)$
 $\Rightarrow n(A) + n(B) - n(A \cap B) = n(A) + n(C) - n(A \cap C)$
 $n(B) = n(C)$

67. If $\vec{u}, \vec{v}, \vec{w}$ are non-coplanar vectors and p, q are real numbers, then the equality $[3\vec{u}, p\vec{v}, p\vec{w}] - [p\vec{v}, \vec{w}, q\vec{u}] - [2\vec{w}, q\vec{v}, q\vec{u}] = 0$ holds for

- (1) exactly one value of (p, q)
(2) exactly two values of (p, q)
(3) more than two but not all values of (p, q)
(4) all values of (p, q)

Key (1)

Sol.: $3p^2 [\vec{u} \vec{v} \vec{w}] - pq [\vec{u} \vec{v} \vec{w}] + 2q^2 [\vec{u} \vec{v} \vec{w}] = 0$
 $\Rightarrow 3p^2 - pq + 2q^2 = 0$
 $p = \frac{q \pm \sqrt{1 - 24}q}{2 \times 3}$
 $p = \frac{q \pm \sqrt{23}iq}{2 \times 3} \Rightarrow p = 0, q = 0$

68. Let the line $\frac{x-2}{3} = \frac{y-1}{-5} = \frac{z+2}{2}$ lie in the plane $x + 3y - \alpha z + \beta = 0$. Then (α, β) equals
 (1) $(6, -17)$ (2) $(-6, 7)$
 (3) $(5, -15)$ (4) $(-5, 5)$

Key: (2)

Sol.: $2 + 3 \times 1 - \alpha(-2) + \beta = 0$
 $2\alpha + \beta = -5 \dots$ (i)
 $3 - 15 - 2\alpha = 0$
 $2\alpha = -12$
 $\alpha = -6$
 $\beta = -5 + 12 = 7$
 $(\alpha, \beta) = (-6, 7)$

69. From 6 different novels and 3 different dictionaries, 4 novels and 1 dictionary are to be selected and arranged in a row on a shelf so that the dictionary is always in the middle. Then the number of such arrangements is
 (1) less than 500
 (2) at least 500 but less than 750
 (3) at least 750 but less than 1000
 (4) at least 1000

Key: (4)

Sol.: $N_1 N_2 N_3 - N_6, D_1 D_2 D_3$
 The number of ways = $6C_4 \times 3C_1 \times 24$
 $= 15 \times 3 \times 24 = 1080$

70. $\int_0^{\pi} [\cot x] dx$, where $[.]$ denotes the greatest integer function, is equal to
 (1) $\pi/2$ (2) 1
 (3) -1 (4) $-\pi/2$

Key: (4)

Sol.: $\int_0^{\pi} [\cot x] dx$
 $\int_0^{\pi/2} \{[\cot x] + [-\cot x]\} dx$
 $= \int_0^{\pi/2} (-1) dx = -\frac{\pi}{2}$

71. For real x , let $f(x) = x^3 + 5x + 1$, then
 (1) f is one-one but not onto \mathbb{R}
 (2) f is onto \mathbb{R} but not one-one
 (3) f is one-one and onto \mathbb{R}
 (4) f is neither one-one nor onto \mathbb{R}

Key: (3)

Sol.: $f(x) = x^3 + 5x + 1$
 $f'(x) = 3x^2 + 5 > 0 \Rightarrow f$ is one-one
 $\therefore f$ is cubic $\Rightarrow f$ is onto
 $\therefore f$ is one-one and onto.

72. In a binomial distribution $B\left(n, p = \frac{1}{4}\right)$, if the probability of at least one success is greater than or equal to $\frac{9}{10}$, then n is greater than

- (1) $\frac{1}{\log_{10}^4 - \log_{10}^3}$ (2) $\frac{1}{\log_{10}^4 + \log_{10}^3}$
 (3) $\frac{9}{\log_{10}^4 - \log_{10}^3}$ (4) $\frac{4}{\log_{10}^4 - \log_{10}^3}$

Key: (1)

Sol.: $P(x \geq 1) \geq \frac{9}{10}$
 $\Rightarrow 1 - P(x = 0) \leq \frac{9}{10}$
 $\Rightarrow \frac{1}{10} \geq \left(\frac{3}{4}\right)^n$
 $\Rightarrow \left(\frac{3}{4}\right)^n \leq \frac{1}{10}$
 $\Rightarrow n[\log_{10}^3 - \log_{10}^4] \leq -1$
 $\Rightarrow n \geq \frac{1}{\log_{10}^4 - \log_{10}^3}$

73. If P and Q are the points of intersection of the circles $x^2 + y^2 + 3x + 7y + 2p - 5 = 0$ and $x^2 + y^2 + 2x + 2y - p^2 = 0$, then there is a circle passing through P, Q and $(1, 1)$ for
 (1) all values of p
 (2) all except one value of p
 (3) all except two values of p
 (4) exactly one value of p

Key: (2)

Sol.: Radical axis is $x + 5y + p^2 + 2p - 5 = 0$
 Equation of circle is
 $x^2 + y^2 + 3x + 7y + 2p - 5 + \lambda [x + 5y + p^2 + 2p - 5] = 0 \dots$ (i)
 (i) passes through $(1, 1)$
 $\Rightarrow \lambda = \frac{-(2p+7)}{(p+1)^2} \quad (p \neq -1)$

74. The projections of a vector on the three coordinate axis are 6, -3, 2 respectively. The direction cosines of the vector are
 (1) 6, -3, 2 (2) $\frac{6}{5}, \frac{-3}{5}, \frac{2}{5}$
 (3) $\frac{6}{7}, \frac{-3}{7}, \frac{2}{7}$ (4) $\frac{-6}{7}, \frac{-3}{7}, \frac{2}{7}$

Key: (3)

Sol.: The DCS are $\frac{6}{7}, \frac{-3}{7}, \frac{2}{7}$.

75. If $\left|Z - \frac{4}{z}\right| = 2$, then the maximum value of $|Z|$ is equal to
 (1) $\sqrt{3} + 1$ (2) $\sqrt{5} + 1$
 (3) $2(4) 2 + \sqrt{2}$

Key: (2)

Sol.: $\left|Z - \frac{4}{z}\right| = 2$

Now, $|z| = \left| z - \frac{4}{z} + \frac{4}{z} \right| \leq 2 + \frac{4}{|z|}$
 $\Rightarrow \frac{|z|^2 - 2|z| - 4|z|}{|z|} \leq 0$
 $\Rightarrow 0 < |z| \leq 1 + \sqrt{5}$.

76. Three distinct points A, B and C are given in the 2-dimensional coordinate plane such that the ratio of the distance of any one of them from the point (1, 0) to the distance from the point (-1, 0) is equal to $\frac{1}{3}$. Then the circumcentre of the triangle ABC is at the point

- (1) (0, 0) (2) $(\frac{5}{4}, 0)$
 (3) $(\frac{5}{2}, 0)$ (4) $(\frac{5}{3}, 0)$

Key : (2)

Sol.: Let the point A is (h, k)

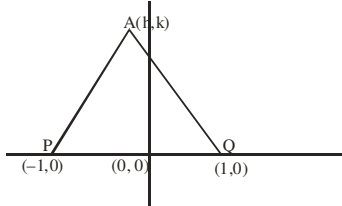

$\frac{AP}{AQ} = \frac{1}{3}$
 $3AP = AQ$
 $\Rightarrow 9AP^2 = AQ^2$
 $\Rightarrow 9[(h-1)^2 + k^2] = (h+1)^2 + k^2$
 $\Rightarrow h^2 + k^2 - \frac{5}{2}h - 1 = 0$

Locus of A(h, k) is

$x^2 + y^2 - \frac{5}{2}x - 1 = 0$

\therefore Circumcentre of ΔABC is $(\frac{5}{4}, 0)$

77. The remainder left out when $8^{2n} - (62)^{2n+1}$ is divided by 9 is

- (1) 0 (2) 2
 (3) 7 (4) 8

Key: (2)

Sol.: $8^{2n} - (62)^{2n+1}$
 $\Rightarrow (9-1)^{2n} - (63-1)^{2n+1}$
 $\Rightarrow {}^{2n}C_0 9^{2n} - {}^{2n}C_1 9^{2n-1} + \dots + {}^{2n}C_{2n}$
 $- ({}^{2n+1}C_0 63^{2n+1} - {}^{2n+1}C_1 63^{2n} + \dots$
 $- {}^{2n+1}C_{2n+1})$

Clearly remainder is '2'.

78. The ellipse $x^2 + 4y^2 = 4$ is inscribed in a rectangle aligned with the coordinate axes, which in turn is inscribed in another ellipse that passes through the point (4, 0). Then the equation of the ellipse is

- (1) $x^2 + 16y^2 = 16$ (2) $x^2 + 12y^2 = 16$

(3) $4x^2 + 48y^2 = 48$ (4) $4x^2 + 64y^2 = 48$

Key (2)

Sol.: Clearly second ellipse is passing through (4, 0) so semi major axis of the ellipse is '4'. If length of semi-minor axis is b then

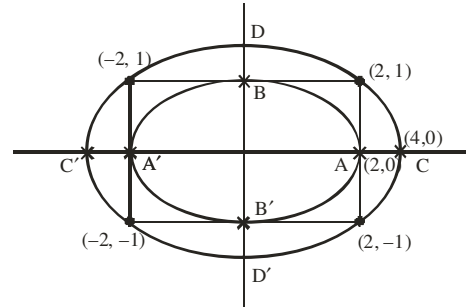

$\frac{x^2}{16} + \frac{y^2}{b^2} = 1$

It passes through (2, 1)

So $\frac{4}{16} + \frac{1}{b^2} = 1$

$\frac{1}{b^2} = \frac{3}{4}$

$b^2 = \frac{4}{3}$

$\Rightarrow x^2 + 12y^2 = 16$

79. The sum to infinity of the series

$1 + \frac{2}{3} + \frac{6}{3^2} + \frac{10}{3^3} + \frac{14}{3^4} + \dots$ is

- (1) 2(2) 3
 (3) 4(4) 6

Key : (2)

Sol.: Let $S = 1 + \frac{2}{3} + \frac{6}{3^2} + \frac{10}{3^3} + \frac{14}{3^4} + \dots$

$\frac{S}{3} = \frac{1}{3} + \frac{2}{3^2} + \frac{6}{3^3} + \frac{10}{3^4} + \dots$

$\frac{2S}{3} = 1 + \frac{1}{3} + \frac{4}{3^2} + \frac{4}{3^3} + \frac{4}{3^4} + \dots$

$= \frac{4}{3} + \frac{\frac{4}{3^2}}{1 - \frac{1}{3}}$

$= \frac{4}{3} + \frac{2}{3} = 2$

$\frac{2S}{3} = 2 \Rightarrow S = 3$

80. The differential equation which represents the family of curves $y = c_1 e^{c_2 x}$, where c_1 and c_2 are arbitrary constants, is

- (1) $y' = y^2$ (2) $y'' = y' y$
 (3) $yy'' = y'$ (4) $yy'' = (y')^2$

Key: (4)

Sol.: $y = c_1 e^{c_2 x} \dots (i)$

$$y' = c_1 c_2 e^{c_2 x}$$

$$y' = c_2 y \dots \dots \text{(from (i))} \dots \dots \text{(ii)}$$

$$y'' = c_2 y' \dots \dots \text{(iii)}$$

$$\text{from (ii) \& (iii) } \frac{y'}{y} = \frac{y''}{y'} \Rightarrow yy'' = (y')^2$$

81. One ticket is selected at random from 50 tickets numbered 00, 01, 02, ... , 49. Then the probability that the sum of the digits on the selected ticket is 8, given that the product of these digits is zero, equals

- (1) 1/14 (2) 1/7
 (3) 5/14 (4) 1/50

Key: (1)

Sol.: A = Events that sum of the digits on selected ticket is 8

$$= \{08, 17, 26, 35, 44\}$$

$$n(A) = 5$$

Event that product of digits is zero

$$= \{00, 01, 02, 03, 04, 05, 06, 07, 08, 09, 10, 20, 30, 40\}$$

$$\Rightarrow n(B) = 14$$

$$P\left(\frac{A}{B}\right) = \frac{5}{14}$$

82. Let y be an implicit function of x defined by $x^{2x} - 2x^x \cot y - 1 = 0$. Then $y'(1)$ equals

- (1) -1 (2) 1
 (3) log 2 (4) -log 2

Key : (1)

Sol.: When $x = 1, y = \frac{\pi}{2}$

$$(x^x - \cot y)^2 = \operatorname{cosec}^2 y$$

$$x^x = \cot y + \operatorname{cosec} y$$

$$\text{when } x = 1, y = \frac{\pi}{2}$$

$$\Rightarrow x^x = \cot y + \operatorname{cosec} y$$

diff. w.r.t. to x

$$x^x(1 + \ln x) = (-\operatorname{cosec}^2 y - \operatorname{cosec} y \cot y) \frac{dy}{dx}$$

$$\text{when } x = 1 \text{ and } y = \frac{\pi}{2}$$

$$\frac{dy}{dx} = -1$$

83. The area of the region bounded by the parabola $(y - 2)^2 = x - 1$, the tangent to the parabola at the point (2, 3) and the x-axis is

- (1) 3 (2) 6
 (3) 9(4) 12

Key: (3)

Sol.: Equation of tangent at (2, 3)

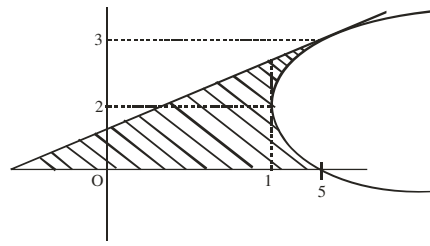

$$\equiv x - 2y + 4 = 0$$

Required area

$$= \int_0^3 [(y-2)^2 + 1 - 2y + 4] dy$$

$$= \int_0^3 [(y-2)^2 - 2y + 5] dy$$

$$= 9 \text{ sq. units}$$

84. Given $P(x) = x^4 + ax^3 + cx + d$ such that $x = 0$ is the only real root of $P'(x) = 0$. If $P(-1) < P(1)$, then in the interval $[-1, 1]$,

- (1) $P(-1)$ is the minimum and $P(1)$ is the maximum of P
 (2) $P(-1)$ is not minimum but $P(1)$ is the maximum of P
 (3) $P(-1)$ is the minimum but $P(1)$ is not the maximum of P
 (3) neither $P(-1)$ is the minimum nor $P(1)$ is the maximum of P
 (4) neither $P(-1)$ is the minimum nor $P(1)$ is the maximum of P

Key: (2)

Sol.: $P(x) = x^4 + ax^3 + bx^2 + cx + d$

$$P'(x) = 4x^3 + 3ax^2 + 2bx + c$$

As $P'(x) = 0$ has only root $x = 0$

$$\Rightarrow c = 0$$

$$P'(x) = x(4x^2 + 3ax + 2b)$$

$$\Rightarrow 4x^2 + 3ax + 2b = 0 \text{ has non real root.}$$

$$\text{and } 4x^2 + 3ax + 2b > 0 \forall x \in [-1, 1].$$

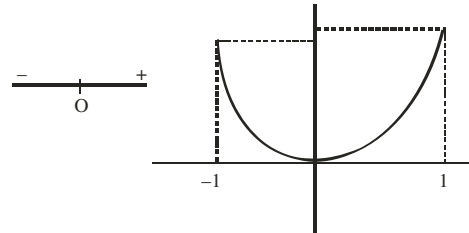

As $P(-1) < P(1) \Rightarrow P(1)$ is the max. of $P(x)$ in $[-1, 1]$

85. The shortest distance between the line $y - x = 1$ and the curve $x = y^2$ is

- (1) $\frac{3\sqrt{2}}{8}$ (2) $\frac{2\sqrt{3}}{8}$
 (3) $\frac{3\sqrt{2}}{5}$ (4) $\frac{\sqrt{3}}{4}$

Key : (1)

Sol.: $1 = 2y \frac{dy}{dx}$

$$\frac{dy}{dx} = \frac{1}{2y} = 1$$

$$\Rightarrow y = \frac{1}{2} \Rightarrow x = \frac{1}{4}$$

$$\text{shortest distance} = \left| \frac{\frac{1}{2} - \frac{1}{4} - 1}{\sqrt{2}} \right| = \frac{3}{4\sqrt{2}} = \frac{3\sqrt{2}}{8}$$

Directions: Questions number 86 – 90 are Assertion– Reason type questions. Each of these questions contains two statements; Statement – 1 (Assertion) and Statement – 2 (Reason)

Each of these questions also have four alternative choices, only one of which is the correct answer. You have to select the correct choice.

86. Let $f(x) = (x + 1)^2 - 1, x \geq -1$
Statement – 1: The set $\{x : f(x) = f^{-1}(x)\} = \{0, -1\}$.

Statement – 2: f is a bijection.

- (1) Statement–1 is true, Statement–2 is true, Statement–2 is a correct explanation for statement–1
(2) Statement–1 is true, Statement–2 is true; Statement–2 is not a correct explanation for statement–1.
(3) Statement–1 is true, statement–2 is false.
(4) Statement–1 is false, Statement–2 is true

Key : (1)

Sol.: $(x + 1)^2 - 1 = x$

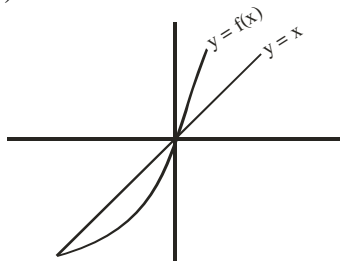

$$(x + 1)^2 = x + 1$$

$$\Rightarrow x = 0, -1$$

Since co-domain of function is not given.

So if we assume function

- (a) as onto then A is correct
(b) as not onto then none of the answer is correct.
87. Let $f(x) = |x|$ and $g(x) = \sin x$
Statement 1 : $g \circ f$ is differentiable at $x = 0$ and its derivative is continuous at that point
Statement 2: $g \circ f$ is twice differentiable at $x = 0$
(1) Statement–1 is true, Statement–2 is true, Statement–2 is a correct explanation for statement–1
(2) Statement–1 is true, Statement–2 is true; Statement–2 is not a correct explanation for statement–1.
(3) Statement–1 is true, statement–2 is false.

- (4) Statement–1 is false, Statement–2 is true

Key : (3)

Sol.: $g(f(x)) = \sin(f(x)) = \begin{cases} \sin x^2, & x \geq 0 \\ -\sin x^2, & x < 0 \end{cases}$

$$(g(f(x)))' = \begin{cases} 2x \cos x^2, & x \geq 0 \\ -2x \cos x^2, & x < 0 \end{cases}$$

$$\text{R.H.D. of } (g(f(0)))' = \lim_{h \rightarrow 0^+} \frac{2h \cosh^2}{h} = 2$$

$$\text{L.H.D. of } (g(f(0)))' = \lim_{h \rightarrow 0^+} \frac{2h \cosh^2}{-h} = -2$$

Clearly $g \circ f$ is twice differentiable at $x = 0$ hence it is differentiable at $x = 0$ and its derivative is continuous at $x = 0$.

88. Statement 1: The variance of first n even natural numbers is $\frac{n^2 - 1}{4}$

Statement 2: The sum of first n natural numbers is $\frac{n(n+1)}{2}$ and the sum of squares of first n natural numbers is $\frac{n(n+1)(2n+1)}{6}$

- (1) Statement–1 is true, Statement–2 is true, Statement–2 is a correct explanation for statement–1
(2) Statement–1 is true, Statement–2 is true; Statement–2 is not a correct explanation for statement–1.
(3) Statement–1 is true, statement–2 is false.
(4) Statement–1 is false, Statement–2 is true

Key : (4)

Sol.: $\bar{x} = \frac{2+4+6+\dots+2n}{n} = n+1$

$$\text{variance } (\sigma^2) = \frac{\sum_{i=1}^n (x_i - \bar{x})^2}{n} = \frac{\sum_{i=1}^n (2i - (n+1))^2}{n}$$

$$= \frac{4 \sum_{i=1}^n i^2 + \sum_{i=1}^n (n+1)^2 - 4(n+1) \sum_{i=1}^n i}{n} = n^2 - 1$$

89. Statement 1: $\sim(p \leftrightarrow \sim q)$ is equivalent to $p \leftrightarrow q$
Statement 2 : $\sim(p \leftrightarrow \sim q)$ is a tautology

- (1) Statement–1 is true, Statement–2 is true, Statement–2 is a correct explanation for statement–1
(2) Statement–1 is true, Statement–2 is true; Statement–2 is not a correct explanation for statement–1.
(3) Statement–1 is true, statement–2 is false.
(4) Statement–1 is false, Statement–2 is true

Key: (3)

Sol.:

p	q	~q	(p ↔ ~q)	~(p ↔ ~q)	p ↔ q
T	T	F	F	T	T
T	F	T	T	F	F
F	T	F	T	F	F
F	F	T	F	T	T

Clearly, $\sim(p \leftrightarrow \sim q)$ is not a tautology because it does not contain T in the column of its truth table. Also, $\sim(p \leftrightarrow \sim q)$ & $p \leftrightarrow q$ have the same truth value.

90. Let A be a 2×2 matrix
 Statement 1 : $\text{adj}(\text{adj} A) = A$
 Statement 2 : $|\text{adj} A| = |A|$
 (1) Statement-1 is true, Statement-2 is true,

Statement-2 is a correct explanation for statement-1

(2) Statement-1 is true, Statement-2 is true; Statement-2 is not a correct explanation for statement-1.

(3) Statement-1 is true, statement-2 is false.

(4) Statement-1 is false, Statement-2 is true

Key: (1)

Sol.: $\text{adj}(\text{adj} A) = |A|^{n-2} A$, where $|A|$ = determinant of A but $n = 2$

$\Rightarrow A$

also $|\text{adj} A| = |A|^{n-1} \Rightarrow |A|$

Statement-1 is true and Statement-2 is also true and Statement-2 is correct explanation of Statement-1.



AIEEE 2009 (KEY)

PHYSICS KEY

1. (3)
2. (1)
3. (3)
4. (1)
5. (2)
6. (1)
7. (4)
8. (3)
9. (4)
10. (2)
11. (4)
12. (2)
13. (2)
14. (3)
15. (4)
16. (2)
17. (2)
18. (2)
19. (3)
20. (1)
21. (2)
22. (4)
23. (3)
24. (1)
25. (4)
26. (1)
27. (4)
28. (3)
29. (1)
30. (2)

CHEMISTRY KEY

31. (3)
32. (4)
33. (3)
34. (3)
35. (3)
36. (3)
37. (4)
38. (4)
39. (3)
40. (4)
41. (3)
42. (3)
43. (3)
44. (2)
45. (2)
46. (4)
47. (2)
48. (1)
49. (1)
50. (2)
51. (2)
52. (2)
53. (3)
54. (2)
55. (2)
56. (3)
57. (3)
58. (2)
59. (2)
60. (3)

MATHS KEY

61. (3)
62. (3)
63. (3)
64. (3)
65. (2)
66. (3)
67. (1)
68. (2)
69. (4)
70. (4)
71. (3)
72. (1)
73. (2)
74. (3)
75. (2)
76. (2)
77. (2)
78. (2)
79. (2)
80. (4)
81. (1)
82. (1)
83. (3)
84. (2)
85. (1)
86. (1)
87. (3)
88. (4)
89. (3)
90. (1)