

Physics

1. A projectile can have the same range R for two angles of projection. If t_1 and t_2 be the times of flights in the two cases, then the product of the two times of flights is proportional to :
 - (a) R^2
 - (b) $\frac{1}{R^2}$
 - (c) $\frac{1}{R}$
 - (d) R

2. An annular ring with inner and outer radii R_1 and R_2 is rolling without slipping with a uniform angular speed. The ratio of the forces experienced by the two particles situated on the inner and outer parts of the ring, $\frac{F_1}{F_2}$ is :
 - (a) $\frac{R_2}{R_1}$
 - (b) $\left(\frac{R_1}{R_2}\right)^2$
 - (c) 1
 - (d) $\frac{R_1}{R_2}$

3. A smooth block is released at rest on a 45° incline and then slides a distance d . The time taken to slide is n times as much to slide on rough incline than on a smooth incline. The coefficient of friction is :
 - (a) $\mu_k = 1 - \frac{1}{n^2}$
 - (b) $\mu_k = \sqrt{1 - \frac{1}{n^2}}$
 - (c) $\mu_s = 1 - \frac{1}{n^2}$
 - (d) $\mu_s = \sqrt{1 - \frac{1}{n^2}}$

4. The upper half of an inclined plane with inclination ϕ is perfectly smooth, while the lower half is rough. A body starting from rest at the top will again come to rest at the bottom, if the coefficient of friction for the lower half is given by :
 - (a) $2 \sin \phi$
 - (b) $2 \cos \phi$
 - (c) $2 \tan \phi$
 - (d) $\tan \phi$

5. A bullet fired into a fixed target loses half of its velocity after penetrating 3cm. How much further it will penetrate before coming to rest, assuming that it faces constant resistance to motion ?
 - (a) 3.0 cm
 - (b) 2.0 cm
 - (c) 1.5 cm
 - (d) 1.0 cm

6. Out of the following pairs, which one does not have identical dimensions ?
 - (a) Angular momentum and Planck's constant
 - (b) Impulse and momentum
 - (c) Moment of inertia and moment of a force
 - (d) Work and torque

7. The relation between time t and distance x is $t = ax^2 + bx$, where a and b are constants. The acceleration is :
 - (a) $-2abv^2$
 - (b) $2bv^3$
 - (c) $-2av^3$
 - (d) $2av^2$

8. A car, starting from rest, accelerates at the rate f through a distance S , then continues at constant speed for time t and then decelerates at the rate $f/2$ to come to rest. If the total distance travelled is $15S$, then :
 - (a) $S = ft$
 - (b) $S = \frac{1}{6}ft^2$
 - (c) $S = \frac{1}{2}ft^2$
 - (d) $S = \frac{1}{4}ft^2$

9. A particle is moving eastwards with a velocity of 5 ms^{-1} . In 10 s the velocity changes to 5 ms^{-1} northwards. The average acceleration in this time is :
 - (a) $\frac{1}{\sqrt{2}} \text{ ms}^{-2}$ towards north-east
 - (b) $\frac{1}{2} \text{ ms}^{-2}$ towards north
 - (c) zero
 - (d) $\frac{1}{2} \text{ ms}^{-2}$ towards north-west

10. A parachutist after bailing out falls 50 m without friction. When parachute opens, it decelerates at 2 m/s^2 . He reaches the ground with a speed of 3 m/s . At what height, did he bail out ?
 - (a) 91 m
 - (b) 182 m
 - (c) 293 m
 - (d) 111 m

11. A block is kept on a frictionless inclined surface with angle of inclination α . The incline is given an acceleration a to keep the block stationary. Then a is equal to :

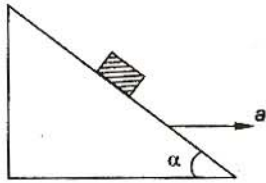

- (a) $g/\tan \alpha$ (b) $g \operatorname{cosec} \alpha$
 (c) g (d) $g \tan \alpha$
12. A spherical ball of mass 20 kg is stationary at the top of a hill of height 100 m. It rolls down a smooth surface to the ground, then climbs up another hill of height 30 m and finally rolls down to a horizontal base at a height of 20 m above the ground. The velocity attained by the ball is :
- (a) 40 m/s (b) 20 m/s
 (c) 10 m/s (d) $10\sqrt{30}$ m/s
13. A body A of mass M while falling vertically downwards under gravity breaks into two parts; a body B of mass $\frac{1}{3}M$ and, a body C of mass $\frac{2}{3}M$. The centre of mass of bodies B and C taken together shifts compared to that of body A towards :
- (a) depends on height of breaking
 (b) does not shift
 (c) body C
 (d) body B
14. The moment of inertia of uniform semicircular disc of mass M and radius r about a line perpendicular to the plane of the disc through the centre is :
- (a) $\frac{1}{4}Mr^2$ (b) $\frac{2}{5}Mr^2$
 (c) Mr^2 (d) $\frac{1}{2}Mr^2$
15. A particle of mass 0.3 kg is subjected to a force $F = -kx$ with $k = 15 \text{ N/m}$. What will be its initial acceleration, if it is released from a point 20 cm away from the origin ?
- (a) 3 m/s^2 (b) 15 m/s^2
 (c) 5 m/s^2 (d) 10 m/s^2
16. The block of mass M moving on the frictionless horizontal surface collides with the spring of

spring constant k and compresses it by length L . The maximum momentum of the block after collision is :

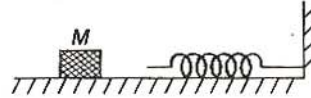

- (a) $\sqrt{Mk} L$ (b) $\frac{kL^2}{2M}$
 (c) zero (d) $\frac{ML^2}{k}$
17. A mass m moves with a velocity v and collides inelastically with another identical mass. After collision the 1st mass moves with velocity $\frac{v}{\sqrt{3}}$ in a direction perpendicular to the initial direction of motion. Find the speed of the second mass after collision :
- (a) v (b) $\sqrt{3} v$
 (c) $\frac{2}{\sqrt{3}} v$ (d) $\frac{v}{\sqrt{3}}$
18. A 20 cm long capillary tube is dipped in water. The water rises upto 8 cm. If the entire arrangement is put in a freely falling elevator, the length of water column in the capillary tube will be :
- (a) 8 cm (b) 10 cm
 (c) 4 cm (d) 20 cm
19. If S is stress and Y is Young's modulus of material of a wire, the energy stored in the wire per unit volume is :
- (a) $2S^2Y$ (b) $\frac{S^2}{2Y}$
 (c) $\frac{2Y}{S^2}$ (d) $\frac{S}{2Y}$
20. Average density of the earth :
- (a) does not depend on g
 (b) is a complex function of g
 (c) is directly proportional to g
 (d) is inversely proportional to g
21. A body of mass m is accelerated uniformly from rest to a speed v in a time T . The instantaneous power delivered to the body as a function of time, is given by :
- (a) $\frac{mv^2}{T^2} t$ (b) $\frac{mv^2}{T^2} t^2$
 (c) $\frac{1}{2} \frac{mv^2}{T^2} t$ (d) $\frac{1}{2} \frac{mv^2}{T^2} t^2$

22. Consider a car moving on a straight road with a speed of 100 m/s. The distance at which car can be stopped, is : [$\mu_k = 0.5$]
- (a) 800 m (b) 1000 m
(c) 100 m (d) 400 m
23. Which of the following is incorrect regarding the first law of thermodynamics ?
- (a) It is not applicable to any cyclic process
(b) It is a restatement of the principle of conservation of energy
(c) It introduces the concept of the internal energy
(d) It introduces the concept of the entropy
24. A T shaped object with dimensions shown in the figure, is lying on a smooth floor. A force \vec{F} is applied at the point P parallel to AB, such that the object has only the translational motion without rotation. Find the location of P with respect to C :

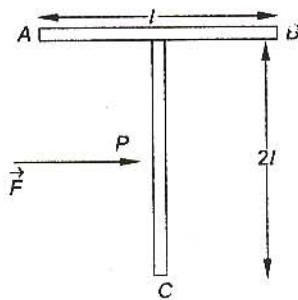

- (a) $\frac{2}{3}l$ (b) $\frac{3}{2}l$
(c) $\frac{4}{3}l$ (d) l
25. The change in the value of g at a height h above the surface of the earth is the same as at a depth d below the surface of earth. When both d and h are much smaller than the radius of earth, then which one of the following is correct ?
- (a) $d = \frac{h}{2}$ (b) $d = \frac{3h}{2}$
(c) $d = 2h$ (d) $d = h$
26. A particle of mass 10 g is kept on the surface of a uniform sphere of mass 100 kg and radius 10 cm. Find the work to be done against the gravitational force between them, to take the particle far away from the sphere : (you may take $G = 6.67 \times 10^{-11} \text{ Nm}^2/\text{kg}^2$)
- (a) $13.34 \times 10^{-10} \text{ J}$ (b) $3.33 \times 10^{-10} \text{ J}$
(c) $6.67 \times 10^{-9} \text{ J}$ (d) $6.67 \times 10^{-10} \text{ J}$

27. A gaseous mixture consists of 16 g of helium and 16 g of oxygen. The ratio $\frac{C_p}{C_v}$ of the mixture is :
- (a) 1.59 (b) 1.62
(c) 1.4 (d) 1.54
28. The intensity of gamma radiation from a given source is I . On passing through 36 mm of lead, it is reduced to $I/8$. The thickness of lead, which will reduce the intensity to $I/2$ will be :
- (a) 6 mm (b) 9 mm
(c) 18 mm (d) 12 mm
29. The electrical conductivity of a semiconductor increases when electromagnetic radiation of wavelength shorter than 2480 nm, is incident on it. The band gap in (eV) for the semiconductor is :
- (a) 1.1 eV (b) 2.5 eV
(c) 0.5 eV (d) 0.7 eV
30. A Photocell is illuminated by a small bright source placed 1 m away. When the same source of light is placed $\frac{1}{2}$ m away, the number of electrons emitted by photocathode would :
- (a) decrease by a factor of 4
(b) increase by a factor of 4
(c) decrease by a factor of 2
(d) increase by a factor of 2
31. Starting with a sample of pure ^{66}Cu , $7/8$ of it decays into Zn in 15 min. The corresponding half-life is :
- (a) 10 min (b) 15 min
(c) 5 min (d) $7\frac{1}{2}$ min
32. If radius of the $^{27}_{13}\text{Al}$ nucleus is estimated to be 3.6 fermi, then the radius of $^{125}_{52}\text{Te}$ nucleus be nearly :
- (a) 6 fermi (b) 8 fermi
(c) 4 fermi (d) 5 fermi
33. The temperature-entropy diagram of a reversible engine cycle is given in the figure. Its efficiency is :

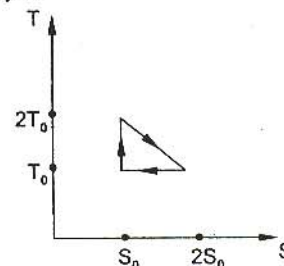

- (a) 1/2 (b) 1/4
(c) 1/3 (d) 2/3

34. The figure shows a system of two concentric spheres of radii r_1 and r_2 and kept at temperatures T_1 and T_2 , respectively. The radial rate of flow of heat in a substance between the two concentric spheres, is proportional to :

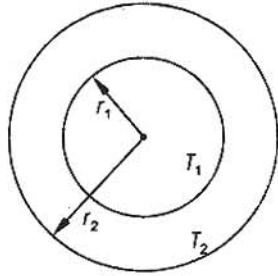

- (a) $\frac{(r_2 - r_1)}{(r_1 r_2)}$ (b) $\ln \left(\frac{r_2}{r_1} \right)$
 (c) $\frac{r_1 r_2}{(r_2 - r_1)}$ (d) $(r_2 - r_1)$
35. A system goes from A to B via two processes I and II as shown in figure. If ΔU_1 and ΔU_2 are the changes in internal energies in the processes I and II respectively, then :

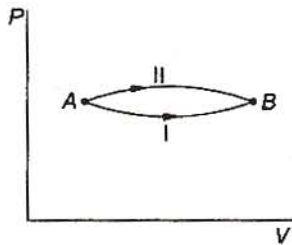

- (a) $\Delta U_1 = \Delta U_2$
 (b) relation between ΔU_1 and ΔU_2 cannot be determined
 (c) $\Delta U_2 > \Delta U_1$
 (d) $\Delta U_2 < \Delta U_1$
36. The function $\sin^2(\omega t)$ represents :
- (a) a periodic, but not simple harmonic, motion with a period $2\pi/\omega$
 (b) a periodic, but not simple harmonic, motion with a period π/ω
 (c) a simple harmonic motion with a period $2\pi/\omega$
 (d) a simple harmonic motion with a period π/ω
37. A Young's double slit experiment uses a monochromatic source. The shape of the interference fringes formed on a screen is :
- (a) hyperbola (b) circle
 (c) straight line (d) parabola

38. Two simple harmonic motions are represented by the equations $y_1 = 0.1 \sin \left(100 \pi t + \frac{\pi}{3} \right)$ and $y_2 = 0.1 \cos \pi t$. The phase difference of the velocity of particle 1, with respect to the velocity of particle 2 is :
- (a) $-\frac{\pi}{6}$ (b) $\frac{\pi}{3}$
 (c) $-\frac{\pi}{3}$ (d) $\frac{\pi}{6}$

39. A fish looking up through the water sees the outside world, contained in a circular horizon. If the refractive index of water is $\frac{4}{3}$ and the fish is 12 cm below the water surface, the radius of this circle in cm is :

- (a) $36\sqrt{7}$ (b) $\frac{36}{\sqrt{7}}$
 (c) $36\sqrt{5}$ (d) $4\sqrt{5}$

40. Two point white dots are 1 mm apart on a black paper. They are viewed by eye of pupil diameter 3 mm. Approximately, what is the maximum distance at which these dots can be resolved by the eye ? [Take wavelength of light = 500 nm]
- (a) 5 m (b) 1 m
 (c) 6 m (d) 3 m

41. A thin glass (refractive index 1.5) lens has optical power of -5 D in air. Its optical power in a liquid medium with refractive index 1.6 will be :
- (a) 1 D (b) -1 D
 (c) 25 D (d) -25 D

42. The diagram shows the energy levels for an electron in a certain atom. Which transition shown represents the emission of a photon with the most energy ?

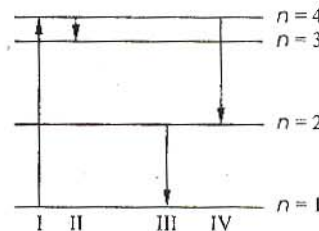

- (a) III (b) IV
 (c) I (d) II

43. If the kinetic energy of a free electron doubles, its de-Broglie wavelength changes by the factor :
- (a) $\frac{1}{2}$ (b) 2
 (c) $\frac{1}{\sqrt{2}}$ (d) $\sqrt{2}$

44. In a common base amplifier, the phase difference between the input signal voltage and output voltage is :

- (a) $\frac{\pi}{4}$ (b) π
 (c) zero (d) $\frac{\pi}{2}$

45. In a full wave rectifier circuit operating from 50 Hz mains frequency, the fundamental frequency in the ripple would be :

- (a) 50 Hz (b) 25 Hz
 (c) 100 Hz (d) 70.7 Hz

46. A nuclear transformation is denoted by $X(n, \alpha) \rightarrow {}^7_3\text{Li}$. Which of the following is the nucleus of element X ?

- (a) ${}^{12}_6\text{C}$ (b) ${}^{10}_5\text{B}$
 (c) ${}^9_5\text{B}$ (d) ${}^{11}_4\text{Be}$

47. A moving coil galvanometer has 150 equal divisions. Its current sensitivity is 10 divisions per milliampere and voltage sensitivity is 2 divisions per millivolt. In order that each division reads 1 V, the resistance in Ohm's needed to be connected in series with the coil will be :

- (a) 10^3 (b) 10^5
 (c) 99995 (d) 9995

48. Two voltmeters, one of copper and another of silver, are joined in parallel. When a total charge q flows through the voltmeters, equal amount of metals are deposited. If the electrochemical equivalents of copper and silver are z_1 and z_2 respectively, the charge which flows through the silver voltmeter is :

- (a) $\frac{q}{1 + \frac{z_1}{z_2}}$ (b) $\frac{q}{1 + \frac{z_2}{z_1}}$
 (c) $q \frac{z_1}{z_2}$ (d) $q \frac{z_2}{z_1}$

49. In the circuit, the galvanometer G shows zero deflection. If the batteries A and B have negligible internal resistance, the value of the resistor R will be :

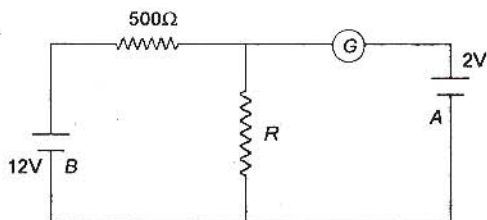

- (a) 200Ω (b) 100Ω
 (c) 500Ω (d) 1000Ω

50. Two sources of equal emf are connected to an external resistance R . The internal resistances of the two sources are R_1 and R_2 ($R_2 > R_1$). If the potential difference across the source having internal resistance R_2 is zero, then :

- (a) $R = \frac{R_2 \times (R_1 + R_2)}{(R_2 - R_1)}$
 (b) $R = R_2 - R_1$
 (c) $R = \frac{R_1 R_2}{(R_1 + R_2)}$
 (d) $R = \frac{R_1 R_2}{(R_2 - R_1)}$

51. A fully charged capacitor has a capacitance C . It is discharged through a small coil of resistance wire embedded in a thermally insulated block of specific heat capacity s and mass m . If the temperature of the block is raised by ΔT , the potential difference V across the capacitance is :

- (a) $\sqrt{\frac{2mC\Delta T}{s}}$ (b) $\frac{mC\Delta T}{s}$
 (c) $\frac{ms\Delta T}{C}$ (d) $\sqrt{\frac{2ms\Delta T}{C}}$

52. One conducting U -tube can slide inside another as shown in figure, maintaining electrical contacts between the tubes. The magnetic field B is perpendicular to the plane of the figure. If each tube moves towards the other at a constant speed v , then the emf induced in the circuit in terms of B , l and v , where l is the width of each tube, will be :

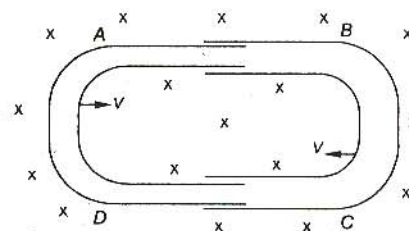

- (a) Blv (b) $-Blv$
 (c) zero (d) $2Blv$

53. A heater coil is cut into two equal parts and only one part is now used in the heater. The heat generated will now be :

- (a) doubled (b) four times
 (c) one-fourth (d) halved

54. Two thin, long, parallel wires, separated by a distance d carry a current of i A in the same direction. They will :

- (a) attract each other with a force of $\frac{\mu_0 i^2}{(2\pi d)}$
 (b) repel each other with a force of $\frac{\mu_0 i^2}{(2\pi d)}$
 (c) attract each other with a force of $\frac{\mu_0 i^2}{(2\pi d^2)}$
 (d) repel each other with a force of $\frac{\mu_0 i^2}{(2\pi d^2)}$

55. When an unpolarized light of intensity I_0 is incident on a polarizing sheet, the intensity of the light which does not get transmitted is :

- (a) $\frac{1}{2} I_0$ (b) $\frac{1}{4} I_0$
 (c) zero (d) I_0

56. A charged ball B hangs from a silk thread S , which makes an angle θ with a large charged conducting sheet P , as shown in the figure. The surface charge density σ of the sheet is proportional to :

- (a) $\cos \theta$ (b) $\cot \theta$
 (c) $\sin \theta$ (d) $\tan \theta$

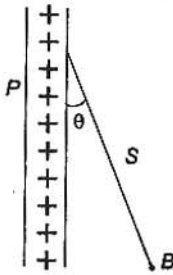

57. Two point charges $+8q$ and $-2q$ are located at $x=0$ and $x=L$ respectively. The location of a point on the x -axis at which the net electric field due to these two point charges is zero is :

- (a) $2L$ (b) $\frac{L}{4}$
 (c) $8L$ (d) $4L$

58. Two thin wire rings each having a radius R are placed at a distance d apart with their axes coinciding. The charges on the two rings are $+q$ and $-q$. The potential difference between the centres of the two rings is :

- (a) $\frac{qR}{4\pi\epsilon_0 d^2}$
 (b) $\frac{q}{2\pi\epsilon_0} \left[\frac{1}{R} - \frac{1}{\sqrt{R^2 + d^2}} \right]$
 (c) zero
 (d) $\frac{q}{4\pi\epsilon_0} \left[\frac{1}{R} - \frac{1}{\sqrt{R^2 + d^2}} \right]$

59. A parallel plate capacitor is made by stacking n equally spaced plates connected alternatively. If the capacitance between any two adjacent plates is C , then the resultant capacitance is :

- (a) $(n-1)C$ (b) $(n+1)C$
 (c) C (d) nC

60. When two tuning forks (fork 1 and fork 2) are sounded simultaneously, 4 beats per second are heard. Now, some tape is attached on the prong of the fork 2. When the tuning forks are sounded again, 6 beats per second are heard. If the frequency of fork 1 is 200 Hz, then what was the original frequency of fork 2 ?

- (a) 200 Hz (b) 202 Hz
 (c) 196 Hz (d) 204 Hz

61. If a simple harmonic motion is represented by $\frac{d^2x}{dt^2} + \alpha x = 0$, its time period is :

- (a) $\frac{2\pi}{\alpha}$ (b) $\frac{2\pi}{\sqrt{\alpha}}$
 (c) $2\pi\alpha$ (d) $2\pi\sqrt{\alpha}$

62. The bob of a simple pendulum is a spherical hollow ball filled with water. A plugged hole near the bottom of the oscillating bob gets suddenly unplugged. During observation, till water is coming out, the time period of oscillation would :

- (a) first increase and then decrease to the original value
 (b) first decrease and then increase to the original value
 (c) remain unchanged
 (d) increase towards a saturation value

63. An observer moves towards a stationary source of sound, with a velocity one-fifth of the velocity of sound. What is the percentage increase in the apparent frequency ?

- (a) Zero (b) 0.5%
 (c) 5% (d) 20%

64. If I_0 is the intensity of the principal maximum in the single slit diffraction pattern, then what will be its intensity when the slit width is doubled ?

- (a) $2I_0$ (b) $4I_0$
 (c) I_0 (d) $\frac{I_0}{2}$

65. Two concentric coils each of radius equal to 2π cm are placed at right angles to each other. 3 A and 4 A are the currents flowing in each coil respectively. The magnetic induction in Wb/m^2 at the centre of the coils will be :

- ($\mu_0 = 4\pi \times 10^{-7} \text{ Wb/Am}$)
 (a) 12×10^{-5} (b) 10^{-5}
 (c) 5×10^{-5} (d) 7×10^{-5}

66. A coil of inductance 300 mH and resistance 2Ω is connected to a source of voltage 2V. The current reaches half of its steady state value in :
 (a) 0.05 s (b) 0.1 s
 (c) 0.15 s (d) 0.3 s
67. The self-inductance of the motor of an electric fan is 10 H. In order to impart maximum power at 50 Hz, it should be connected to a capacitance of :
 (a) $4\mu\text{F}$ (b) $8\mu\text{F}$
 (c) $1\mu\text{F}$ (d) $2\mu\text{F}$
68. An energy source will supply a constant current into the load, if its internal resistance is :
 (a) equal to the resistance of the load
 (b) very large as compared to the load resistance
 (c) zero
 (d) non-zero but less than the resistance of the load
69. A circuit has a resistance of 12Ω and an impedance of 15Ω . The power factor of the circuit will be :
 (a) 0.8 (b) 0.4
 (c) 1.25 (d) 0.125
70. The phase difference between the alternating current and emf is $\pi/2$. Which of the following cannot be the constituent of the circuit ?
 (a) C alone (b) R, L
 (c) L, C (d) L alone
71. A uniform electric field and a uniform magnetic field are acting along the same direction in a certain region. If an electron is projected along the direction of the fields with a certain velocity, then :
 (a) its velocity will decrease
 (b) its velocity will increase
 (c) it will turn towards right of direction of motion
 (d) it will turn towards left of direction of motion
72. A charged particle of mass m and charge q travels on a circular path of radius r that is perpendicular to a magnetic field B . The time taken by the particle to complete one revolution is :
 (a) $\frac{2\pi m q}{B}$ (b) $\frac{2\pi q^2 B}{m}$
 (c) $\frac{2\pi q B}{m}$ (d) $\frac{2\pi m}{q B}$
73. In a potentiometer experiment the balancing with a cell is at length 240 cm. On shunting the cell with a resistance of 2Ω , the balancing length becomes 120 cm. The internal resistance of the cell is :
 (a) 1Ω (b) 0.5Ω
 (c) 4Ω (d) 2Ω
74. The resistance of hot tungsten filament is about 10 times the cold resistance. What will be the resistance of 100 W and 200 V lamp, when not in use ?
 (a) 40Ω (b) 20Ω
 (c) 400Ω (d) 200Ω
75. A magnetic needle is kept in a non-uniform magnetic field. It experiences :
 (a) a torque but not a force
 (b) neither a force nor a torque
 (c) a force and a torque
 (d) a force but not a torque

Chemistry

76. The oxidation state of Cr in $[\text{Cr}(\text{NH}_3)_4\text{Cl}_2]^+$ is :
 (a) 0 (b) +1
 (c) +2 (d) +3
77. Which one of the following types of drugs reduces fever ?
 (a) Tranquiliser (b) Antibiotic
 (c) Antipyretic (d) Analgesic
78. Which of the following oxides is amphoteric in character ?
 (a) SnO_2 (b) SiO_2
 (c) CO_2 (d) CaO
79. Which one of the following species is diamagnetic in nature ?
 (a) H_2^- (b) H_2^+
 (c) H_2 (d) He_2^+
80. If α is the degree of dissociation of Na_2SO_4 , the van't Hoff factor (i) used for calculating the molecular mass is :
 (a) $1 - 2\alpha$ (b) $1 + 2\alpha$
 (c) $1 - \alpha$ (d) $1 + \alpha$
81. Which of the following is a polyamide ?
 (a) Bakelite (b) Terylene
 (c) Nylon-66 (d) Teflon

82. Due to the presence of an unpaired electron, free radicals are :
- cations
 - anions
 - chemically inactive
 - chemically reactive
83. For a spontaneous reaction the ΔG , equilibrium constant (K) and E_{cell}° will be respectively :
- ve, > 1 , -ve
 - ve, < 1 , -ve
 - +ve, > 1 , -ve
 - ve, > 1 , +ve
84. Hydrogen bomb is based on the principle of :
- artificial radioactivity
 - nuclear fusion
 - natural radioactivity
 - nuclear fission
85. An ionic compound has a unit cell consisting of A ions at the corners of a cube and B ions on the centres of the faces of the cube. The empirical formula for this compound would be :
- A_3B
 - AB_3
 - A_2B
 - AB
86. The highest electrical conductivity of the following aqueous solutions is of :
- 0.1 M difluoroacetic acid
 - 0.1 M fluoroacetic acid
 - 0.1 M chloroacetic acid
 - 0.1 M acetic acid
87. Lattice energy of an ionic compound depends upon :
- charge on the ion and size of the ion
 - packing of ions only
 - size of the ion only
 - charge on the ion only
88. Consider an endothermic reaction $X \rightarrow Y$ with the activation energies E_b and E_f for the backward and forward reactions respectively. In general :
- there is no definite relation between E_b and E_f
 - $E_b = E_f$
 - $E_b > E_f$
 - $E_b < E_f$
89. Aluminium oxide may be electrolysed at 1000°C to furnish aluminium metal (Atomic mass = 27 amu; 1 faraday = 96,500 Coulombs). The cathode reaction is
- $$\text{Al}^{3+} + 3e^{-} \rightarrow \text{Al}^0$$
- To prepare 5.12 kg of aluminium metal by this method would require :
- 5.49×10^1 C of electricity
 - 5.49×10^4 C of electricity
 - 1.83×10^7 C of electricity
 - 5.49×10^7 C of electricity
90. The volume of a colloidal particle, V_c as compared to the volume of a solute particle in a true solution V_s , could be :
- $\frac{V_c}{V_s} \approx 10^3$
 - $\frac{V_c}{V_s} \approx 10^{-3}$
 - $\frac{V_c}{V_s} \approx 10^{23}$
 - $\frac{V_c}{V_s} \approx 1$
91. Consider the reaction : $\text{N}_2 + 3\text{H}_2 \rightarrow 2\text{NH}_3$ carried out at constant temperature and pressure. If ΔH and ΔU are the enthalpy and internal energy changes for the reaction, which of the following expressions is true ?
- $\Delta H > \Delta U$
 - $\Delta H < \Delta U$
 - $\Delta H = \Delta U$
 - $\Delta H = 0$
92. The solubility product of a salt having general formula MX_2 , in water is 4×10^{-12} . The concentration of M^{2+} ions in the aqueous solution of the salt is :
- 4.0×10^{-10} M
 - 1.6×10^{-4} M
 - 1.0×10^{-4} M
 - 2.0×10^{-6} M
93. Benzene and toluene form nearly ideal solutions. At 20°C , the vapour pressure of benzene is 75 torr and that of toluene is 22 torr. The partial vapour pressure of benzene at 20°C for a solution containing 78 g of benzene and 46 g of toluene in torr is :
- 53.5
 - 37.5
 - 25
 - 50
94. Which one of the following statements is not true about the effect of an increase in temperature on the distribution of molecular speeds in a gas ?
- The area under the distribution curve remains the same as under the lower temperature
 - The distribution becomes broader
 - The fraction of the molecules with the most probable speed increases
 - The most probable speed increases
95. For the reaction
- $$2\text{NO}_2(\text{g}) \rightleftharpoons 2\text{NO}(\text{g}) + \text{O}_2(\text{g})$$
- ($K_c = 1.8 \times 10^{-6}$ at 184°C)
 ($R = 0.00831 \text{ kJ}/(\text{mol} \cdot \text{K})$)
 When K_p and K_c are compared at 184°C it is found that :

- (a) whether K_p is greater than, less than or equal to K_c depends upon the total gas pressure
- (b) $K_p = K_c$
- (c) K_p is less than K_c
- (d) K_p is greater than K_c
96. The exothermic formation of ClF_3 is represented by the equation :
 $\text{Cl}_2(\text{g}) + 3 \text{F}_2(\text{g}) \rightleftharpoons 2 \text{ClF}_3(\text{g}); \Delta H_r = -329 \text{ kJ}$
 Which of the following will increase the quantity of ClF_3 in an equilibrium mixture of Cl_2 , F_2 and ClF_3 ?
- (a) Adding F_2
- (b) Increasing the volume of the container
- (c) Removing Cl_2
- (d) Increasing the temperature
97. Hydrogen ion concentration in mol/L in a solution of $\text{pH} = 5.4$ will be :
- (a) 3.98×10^{-6} (b) 3.68×10^{-6}
- (c) 3.88×10^6 (d) 3.98×10^8
98. A reaction involving two different reactants can never be
- (a) bimolecular reaction
- (b) second order reaction
- (c) first order reaction
- (d) unimolecular reaction
99. Two solutions of a substance (non electrolyte) are mixed in the following manner.
 480 mL of 1.5 M first solution + 520 mL of 1.2 M second solution.
 What is the molarity of the final mixture ?
- (a) 2.70 M (b) 1.344 M
- (c) 1.50 M (d) 1.20 M
100. During the process of electrolytic refining of copper, some metals present as impurity settle as 'anode mud'. These are :
- (a) Fe and Ni (b) Ag and Au
- (c) Pb and Zn (d) Se and Ag
101.

Electrolyte	KCl	KNO_3	HCl	NaOAc	NaCl
$\Lambda^\infty (\text{S cm}^2 \text{ mol}^{-1})$	149.9	145.0	426.2	91.0	126.5

 Calculate $\Lambda^\infty_{\text{HOAc}}$ using appropriate molar conductances of the electrolytes listed above at infinite dilution in H_2O at 25°C :
- (a) 217.5 (b) 390.7
- (c) 552.7 (d) 517.2
102. If we consider that $1/6$, in place of $1/12$, mass of carbon atom is taken to be the relative atomic mass unit, the mass of one mole of a substance will :

- (a) be a function of the molecular mass of the substance
- (b) remain unchanged
- (c) increase two fold
- (d) decrease twice
103. In a multi-electron atom, which of the following orbitals described by the three quantum numbers will have the same energy in the absence of magnetic and electric fields ?
- (A) $n = 1, l = 0, m = 0$
- (B) $n = 2, l = 0, m = 0$
- (C) $n = 2, l = 1, m = 1$
- (D) $n = 3, l = 2, m = 1$
- (E) $n = 3, l = 2, m = 0$
- (a) (D) and (E) (b) (C) and (D)
- (c) (B) and (C) (d) (A) and (B)
104. Based on lattice energy and other considerations which one of the following alkali metal chlorides is expected to have the highest melting point ?
- (a) RbCl (b) KCl
- (c) NaCl (d) LiCl
105. A schematic plot of $\ln K_{eq}$ versus inverse of temperature for a reaction is shown below :

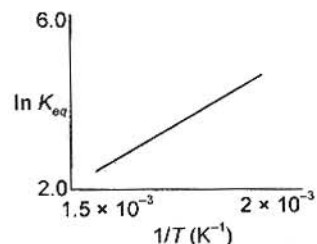

The reaction must be :

- (a) highly spontaneous at ordinary temperature
- (b) one with negligible enthalpy change
- (c) endothermic
- (d) exothermic
106. Heating mixture of Cu_2O and Cu_2S will give
- (a) Cu_2SO_3 (b) $\text{CuO} + \text{CuS}$
- (c) $\text{Cu} + \text{SO}_3$ (d) $\text{Cu} + \text{SO}_2$
107. The molecular shapes of SF_4 , CF_4 and XeF_4 are :
- (a) different with 1, 0 and 2 lone pairs of electrons on the central atom, respectively
- (b) different with 0, 1 and 2 lone pairs of electrons on the central atom, respectively
- (c) the same with 1, 1 and 1 lone pair of electrons on the central atoms, respectively
- (d) the same with 2, 0 and 1 lone pairs of electrons on the central atom, respectively

108. The disperse phase in colloidal iron (III) hydroxide and colloidal gold is positively and negatively charged, respectively. Which of the following statements is not correct ?
- Coagulation in both sols can be brought about by electrophoresis
 - Mixing the sols has no effect
 - Sodium sulphate solution causes coagulation in both sols
 - Magnesium chloride solution coagulates, the gold sol more readily than the iron (III) hydroxide sol.
109. The number of hydrogen atom(s) attached to phosphorus atom in hypophosphorous acid is :
- three
 - one
 - two
 - zero
110. What is the conjugate base of OH^- ?
- O^{2-}
 - O^-
 - H_2O
 - O_2
111. Heating an aqueous solution of aluminium chloride to dryness will give :
- $\text{Al}(\text{OH})\text{Cl}_2$
 - Al_2O_3
 - Al_2Cl_6
 - AlCl_3
112. The correct order of the thermal stability of hydrogen halides ($\text{H}-\text{X}$) is :
- $\text{HI} > \text{HCl} < \text{HF} > \text{HBr}$
 - $\text{HCl} < \text{HF} > \text{HBr} < \text{HI}$
 - $\text{HF} > \text{HCl} > \text{HBr} > \text{HI}$
 - $\text{HI} > \text{HBr} > \text{HCl} > \text{HF}$
113. Calomel (Hg_2Cl_2) on reaction with ammonium hydroxide gives :
- HgO
 - Hg_2O
 - $\text{NH}_2-\text{Hg}-\text{Hg}-\text{Cl}$
 - HgNH_2Cl
114. The number and type of bonds between two carbon atoms in calcium carbide are :
- two sigma, two pi
 - two sigma, one pi
 - one sigma, two pi
 - one sigma, one pi
115. The oxidation state of chromium in the final product formed by the reaction between KI and acidified potassium dichromate solution is :
- +3
 - +2
 - +6
 - +4
116. In silicon dioxide :
- there are double bonds between silicon and oxygen atoms
 - silicon atom is bonded to two oxygen atoms
 - each silicon atom is surrounded by two oxygen atoms and each oxygen atom is bonded to two silicon atoms
 - each silicon atom is surrounded by four oxygen atoms and each oxygen atom is bonded to two silicon atoms
117. The lanthanide contraction is responsible for the fact that :
- Zr and Zn have the same oxidation state
 - Zr and Hf have about the same radius
 - Zr and Nb have similar oxidation state
 - Zr and Y have about the same radius
118. The IUPAC name of the co-ordination compound $\text{K}_3[\text{Fe}(\text{CN})_6]$ is :
- Tripotassium hexacyanoiron (II)
 - Potassium hexacyanoiron (II)
 - Potassium hexacyanoferrate (III)
 - Potassium hexacyanoferrate (II)
119. In which of the following arrangements the order is not according to the property indicated against it ?
- $\text{Li} < \text{Na} < \text{K} < \text{Rb}$: Increasing metallic radius
 - $\text{I} < \text{Br} < \text{F} < \text{Cl}$: Increasing electron gain enthalpy (with negative sign)
 - $\text{B} < \text{C} < \text{N} < \text{O}$: Increasing first ionisation enthalpy
 - $\text{Al}^{3+} < \text{Mg}^{2+} < \text{Na}^+ < \text{F}^-$: Increasing ionic size
120. Of the following sets which one does not contain isoelectronic species ?
- BO_3^{3-} , CO_3^{2-} , NO_3^-
 - SO_3^{2-} , CO_3^{2-} , NO_3^-
 - CN^- , N_2 , C_2^{2-}
 - PO_4^{3-} , SO_4^{2-} , ClO_4^-
121. 2-methylbutane on reacting with bromine in the presence of sunlight gives mainly :
- 1-bromo-3-methylbutane
 - 2-bromo-3-methylbutane
 - 2-bromo-2-methylbutane
 - 1-bromo-2-methylbutane
122. Which of the following compounds shows optical isomerism ?
- $[\text{Co}(\text{CN})_6]^{3-}$
 - $[\text{Cr}(\text{C}_2\text{O}_4)_3]^{3-}$
 - $[\text{ZnCl}_4]^{2-}$
 - $[\text{Cu}(\text{NH}_3)_4]^{2+}$
123. Which one of the following cyano complexes would exhibit the lowest value of paramagnetic behaviour ?

- (a) $[\text{Co}(\text{CN})_6]^{3-}$ (b) $[\text{Fe}(\text{CN})_6]^{3-}$
 (c) $[\text{Mn}(\text{CN})_6]^{3-}$ (d) $[\text{Cr}(\text{CN})_6]^{3-}$
 (Atomic no. Cr = 24, Mn = 25, Fe = 26, Co = 27)
- 124.** The best reagent to convert pent-3-en-2-ol into pent-3-en-2-one is :
 (a) pyridinium chloro-chromate
 (b) chromic anhydride in glacial acetic acid
 (c) acidic dichromate
 (d) acidic permanganate
- 125.** A photon of hard gamma radiation knocks a proton out of $^{24}_{12}\text{Mg}$ nucleus to form :
 (a) the isobar of $^{23}_{11}\text{Na}$
 (b) the nuclide $^{23}_{11}\text{Na}$
 (c) the isobar of parent nucleus
 (d) the isotope of parent nucleus
- 126.** Reaction of one molecule of HBr with one molecule of 1, 3-butadiene at 40°C gives predominantly :
 (a) 1-bromo-2-butene under kinetically controlled conditions
 (b) 3-bromobutene under thermodynamically controlled conditions
 (c) 1-bromo-2-butene under thermodynamically controlled conditions
 (d) 3-bromobutene under kinetically controlled conditions
- 127.** The decreasing order of nucleophilicity among the nucleophiles :
 (A) $\text{CH}_3\text{C}(\text{O})\text{O}^-$
 $\begin{array}{c} \text{O} \\ || \\ \text{O} \end{array}$
 (B) CH_3O^-
 (C) CN^-
 (D) $\text{H}_3\text{C}-\text{C}_6\text{H}_4-\text{S}(\text{O})_2\text{O}^-$
 $\begin{array}{c} \text{O} \\ || \\ \text{S} \\ || \\ \text{O} \end{array}$
 (a) (C), (B), (A), (D)
 (b) (B), (C), (A), (D)
 (c) (D), (C), (B), (A)
 (d) (A), (B), (C), (D)
- 128.** Tertiary alkyl halides are practically inert to substitution by $\text{S}_{\text{N}}2$ mechanism because of :
 (a) steric hindrance (b) inductive effect
 (c) instability (d) insolubility
- 129.** In both DNA and RNA, heterocyclic base and phosphate ester linkages are at :
 (a) C'_5 and C'_1 respectively of the sugar molecule
 (b) C'_1 and C'_5 respectively of the sugar molecule
 (c) C'_2 and C'_5 respectively of the sugar molecule
 (d) C'_5 and C'_2 respectively of the sugar molecule
- 130.** Among the following acids which has the lowest $\text{p}K_{\text{a}}$ value ?
 (a) $\text{CH}_3\text{CH}_2\text{COOH}$ (b) $(\text{CH}_3)_2\text{CH}-\text{COOH}$
 (c) HCOOH (d) CH_3COOH
- 131.** Of the five isomeric hexanes, the isomer which can give two monochlorinated compounds is :
 (a) 2-methylpentane
 (b) 2, 2-dimethylbutane
 (c) 2, 3-dimethylbutane
 (d) n-hexane
- 132.** Alkyl halides react with dialkyl copper reagents to give :
 (a) alkenyl halides
 (b) alkanes
 (c) alkyl copper halides
 (d) alkenes
- 133.** Which one of the following methods is neither meant for the synthesis nor for separation of amines ?
 (a) Curtius reaction
 (b) Wurtz reaction
 (c) Hofmann method
 (d) Hinsberg method
- 134.** Which types of isomerism is shown by 2, 3-dichlorobutane ?
 (a) Structural (b) Geometric
 (c) Optical (d) Diastereo
- 135.** Amongst the following the most basic compound is :
 (a) p-nitroaniline (b) acetanilide
 (c) aniline (d) benzylamine
- 136.** Acid catalyzed hydration of alkenes except ethene leads to the formation of :
 (a) mixture of secondary and tertiary alcohols
 (b) mixture of primary and secondary alcohols
 (c) secondary or tertiary alcohol
 (d) primary alcohol
- 137.** Which of the following is fully fluorinated polymer ?
 (a) PVC (b) Thiokol
 (c) Teflon (d) Neoprene

138. Elimination of bromine from 2-bromobutane results in the formation of :
- predominantly 2-butyne
 - predominantly 1-butene
 - predominantly 2-butene
 - equimolar mixture of 1 and 2-butene

139. Equimolar solutions in the same solvent have :
- different boiling and different freezing points
 - same boiling and same freezing points
 - same freezing point but different boiling point
 - same boiling point but different freezing point

140. The reaction

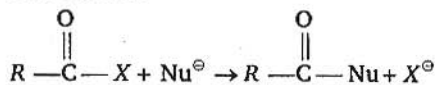

is fastest when X is :

- OCOR
 - OC₂H₅
 - NH₂
 - Cl
141. The structure of diborane (B₂H₆) contains :
- four 2C-2e⁻ bonds and four 3C-2e⁻ bonds
 - two 2C-2e⁻ bonds and two 3C-3e⁻ bonds
 - two 2C-2e⁻ bonds and four 3C-2e⁻ bonds
 - four 2C-2e⁻ bonds and two 3C-2e⁻ bonds
142. Which of the following statements in relation to the hydrogen atom is correct ?
- 3s, 3p and 3d orbitals all have the same energy
 - 3s and 3p orbitals are of lower energy than 3d orbital
 - 3p orbital is lower in energy than 3d orbital
 - 3s orbital is lower in energy than 3p orbital
143. Which of the following factors may be regarded as the main cause of lanthanide contraction ?
- Greater shielding of 5d electron by 4f electrons
 - Poorer shielding of 5d electron by 4f electrons
 - Effective shielding of one of 4f electrons by another in the sub-shell
 - Poor shielding of one of 4f electron by another in the sub-shell
144. The value of the 'spin only' magnetic moment for one of the following configurations is 2.84 BM. The correct one is :
- d⁵ (in strong ligand field)
 - d³ (in weak as well as in strong fields)
 - d⁴ (in weak ligand field)
 - d⁴ (in strong ligand field)

145. Reaction of cyclohexanone with dimethylamine in the presence of catalytic amount of an acid forms a compound. Water during the reaction is continuously removed. The compound formed is generally known as :
- an amine
 - an imine
 - an enamine
 - a Schiff's base

146. *p*-resol reacts with chloroform in alkaline medium to give the compound A which adds hydrogen cyanide to form the compound B. The latter on acidic hydrolysis gives chiral carboxylic acid. The structure of the carboxylic acid is :

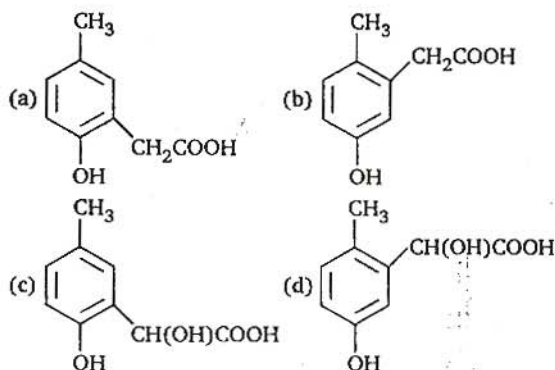

147. If the bond dissociation energies of XY, X₂ and Y₂ (all diatomic molecules) are in the ratio of 1 : 1 : 0.5 and ΔH_f for the formation of XY is -200 kJ mol⁻¹. The bond dissociation energy of X₂ will be :
- 400 kJ mol⁻¹
 - 300 kJ mol⁻¹
 - 200 kJ mol⁻¹
 - none of these
148. An amount of solid NH₄HS is placed in a flask already containing ammonia gas at a certain temperature and 0.50 atm pressure. Ammonium hydrogen sulphide decomposes to yield NH₃ and H₂S gases in the flask. When the decomposition reaction reaches equilibrium, the total pressure in the flask rises to 0.84 atm. The equilibrium constant for NH₄HS decomposition at this temperature is :
- 0.11
 - 0.17
 - 0.18
 - 0.30
149. An organic compound having molecular mass 60 is found to contain C = 20%, H = 6.67% and N = 46.67% while rest is oxygen. On heating it gives NH₃ alongwith a solid residue. The solid residue give violet colour with alkaline copper sulphate solution. The compound is :

- (a) $\text{CH}_3\text{CH}_2\text{CONH}_2$ (b) $(\text{NH}_2)_2\text{CO}$
 (c) CH_3CONH_2 (d) CH_3NCO

150. $t_{1/4}$ can be taken as the time taken for the concentration of a reactant to drop to $\frac{3}{4}$ of its

initial value. If the rate constant for a first order reaction is k , the $t_{1/4}$ can be written as :

- (a) $0.75/k$ (b) $0.69/k$
 (c) $0.29/k$ (d) $0.10/k$

Mathematics

1. If C is the mid point of AB and P is any point outside AB , then :

(a) $\vec{PA} + \vec{PB} + \vec{PC} = \vec{0}$

(b) $\vec{PA} + \vec{PB} + 2\vec{PC} = \vec{0}$

(c) $\vec{PA} + \vec{PB} = \vec{PC}$

(d) $\vec{PA} + \vec{PB} = 2\vec{PC}$

2. Let P be the point $(1, 0)$ and Q a point on the locus $y^2 = 8x$. The locus of mid point of PQ is :

(a) $x^2 - 4y + 2 = 0$ (b) $x^2 + 4y + 2 = 0$

(c) $y^2 + 4x + 2 = 0$ (d) $y^2 - 4x + 2 = 0$

3. If in a frequency distribution, the Mean and Median are 21 and 22 respectively, then its Mode is approximately :

(a) 24.0 (b) 25.5

(c) 20.5 (d) 22.0

4. Let $R = \{(3, 3), (6, 6), (9, 9), (12, 12), (6, 12), (3, 9), (3, 12), (3, 6)\}$ be a relation on the set $A = \{3, 6, 9, 12\}$. The relation is :

(a) reflexive and symmetric only

(b) an equivalence relation

(c) reflexive only

(d) reflexive and transitive only

5. If $A^2 - A + I = 0$, then the inverse of A is :

(a) $I - A$ (b) $A - I$

(c) A (d) $A + I$

6. If the cube roots of unity are $1, \omega, \omega^2$, then the roots of the equation $(x - 1)^3 + 8 = 0$, are :

(a) $-1, 1 + 2\omega, 1 + 2\omega^2$

(b) $-1, 1 - 2\omega, 1 - 2\omega^2$

(c) $-1, -1, -1$

(d) $-1, -1 + 2\omega, -1 - 2\omega^2$

7. $\lim_{n \rightarrow \infty} \left[\frac{1}{n^2} \sec^2 \frac{1}{n^2} + \frac{2}{n^2} \sec^2 \frac{4}{n^2} + \dots + \frac{n}{n^2} \sec^2 1 \right]$

equals :

(a) $\frac{1}{2} \tan 1$

(b) $\tan 1$

(c) $\frac{1}{2} \operatorname{cosec} 1$

(d) $\frac{1}{2} \sec 1$

8. Area of the greatest rectangle that can be inscribed in the ellipse $\frac{x^2}{a^2} + \frac{y^2}{b^2} = 1$ is :

(a) $\frac{a}{b}$

(b) \sqrt{ab}

(c) ab

(d) $2ab$

9. The differential equation representing the family of curves $y^2 = 2c(x + \sqrt{c})$, where $c > 0$, is a parameter, is of order and degree as follows :

(a) order 2, degree 2

(b) order 1, degree 3

(c) order 1, degree 1

(d) order 1, degree 2

10. ABC is a triangle. Forces $\vec{P}, \vec{Q}, \vec{R}$ acting along IA, IB and IC respectively are in equilibrium, where I is the incentre of $\triangle ABC$. Then $\vec{P} : \vec{Q} : \vec{R}$ is :

(a) $\cos A : \cos B : \cos C$

(b) $\cos \frac{A}{2} : \cos \frac{B}{2} : \cos \frac{C}{2}$

(c) $\sin \frac{A}{2} : \sin \frac{B}{2} : \sin \frac{C}{2}$

(d) $\sin A : \sin B : \sin C$

11. If the coefficients of r th, $(r + 1)$ th and $(r + 2)$ th terms in the binomial expansion of $(1 + y)^m$ are in AP, then m and r satisfy the equation :

(a) $m^2 - m(4r - 1) + 4r^2 + 2 = 0$

(b) $m^2 - m(4r + 1) + 4r^2 - 2 = 0$

(c) $m^2 - m(4r + 1) + 4r^2 + 2 = 0$

(d) $m^2 - m(4r - 1) + 4r^2 - 2 = 0$

12. In a triangle PQR , $\angle R = \frac{\pi}{2}$. If $\tan \left(\frac{P}{2} \right)$ and $\tan \left(\frac{Q}{2} \right)$ are the roots of $ax^2 + bx + c = 0$, $a \neq 0$, then :

(a) $b = a + c$

(b) $b = c$

(c) $c = a + b$

(d) $a = b + c$

13. If the letters of the word SACHIN are arranged in all possible ways and these words are written out as in dictionary, then the word SACHIN appears at serial number :
 (a) 602 (b) 603
 (c) 600 (d) 601
14. The value of ${}^{50}C_4 + \sum_{r=1}^6 {}^{56-r}C_3$ is :
 (a) ${}^{56}C_4$ (b) ${}^{56}C_3$
 (c) ${}^{55}C_3$ (d) ${}^{55}C_4$
15. If $A = \begin{bmatrix} 1 & 0 \\ 1 & 1 \end{bmatrix}$ and $I = \begin{bmatrix} 1 & 0 \\ 0 & 1 \end{bmatrix}$, then which one of the following holds for all $n \geq 1$, by the principle of mathematical induction ?
 (a) $A^n = 2^{n-1}A + (n-1)I$
 (b) $A^n = nA + (n-1)I$
 (c) $A^n = 2^{n-1}A - (n-1)I$
 (d) $A^n = nA - (n-1)I$
16. If the coefficient of x^7 in $\left[ax^2 + \left(\frac{1}{bx}\right)\right]^{11}$ equals the coefficient of x^{-7} in $\left[ax - \left(\frac{1}{bx^2}\right)\right]^{11}$, then a and b satisfy the relation :
 (a) $ab = 1$ (b) $\frac{a}{b} = 1$
 (c) $a + b = 1$ (d) $a - b = 1$
17. Let $f : (-1, 1) \rightarrow B$, be a function defined by $f(x) = \tan^{-1} \frac{2x}{1-x^2}$, then f is both one-one and onto when B is the interval :
 (a) $\left(-\frac{\pi}{2}, \frac{\pi}{2}\right)$ (b) $\left[-\frac{\pi}{2}, \frac{\pi}{2}\right]$
 (c) $\left[0, \frac{\pi}{2}\right)$ (d) $\left(0, \frac{\pi}{2}\right)$
18. If z_1 and z_2 are two non-zero complex numbers such that $|z_1 + z_2| = |z_1| + |z_2|$, then $\arg z_1 - \arg z_2$ is equal to :
 (a) $-\frac{\pi}{2}$ (b) 0
 (c) $-\pi$ (d) $\frac{\pi}{2}$
19. If $w = \frac{z}{z - \frac{1}{3}i}$ and $|w| = 1$, then z lies on :
 (a) a parabola (b) a straight line
 (c) a circle (d) an ellipse
20. If $a^2 + b^2 + c^2 = -2$ and

$$f(x) = \begin{vmatrix} 1 + a^2x & (1 + b^2)x & (1 + c^2)x \\ (1 + a^2)x & 1 + b^2x & (1 + c^2)x \\ (1 + a^2)x & (1 + b^2)x & 1 + c^2x \end{vmatrix}$$
 then $f(x)$ is a polynomial of degree :
 (a) 2 (b) 3
 (c) 0 (d) 1
21. The system of equations
 $\alpha x + y + z = \alpha - 1$
 $x + \alpha y + z = \alpha - 1$
 $x + y + \alpha z = \alpha - 1$
 has no solution, if α is :
 (a) 1 (b) not -2
 (c) either -2 or 1 (d) -2
22. The value of a for which the sum of the squares of the roots of the equation $x^2 - (a-2)x - a - 1 = 0$ assume the least value is :
 (a) 2 (b) 3
 (c) 0 (d) 1
23. If the roots of the equation $x^2 - bx + c = 0$ be two consecutive integers, then $b^2 - 4c$ equals :
 (a) 1 (b) 2
 (c) 3 (d) -2
24. Suppose $f(x)$ is differentiable at $x=1$ and $\lim_{h \rightarrow 0} \frac{1}{h} f(1+h) = 5$, then $f'(1)$ equals :
 (a) 6 (b) 5
 (c) 4 (d) 3
25. Let f be differentiable for all x . If $f(1) = -2$ and $f'(x) \geq 2$ for $x \in [1, 6]$, then :
 (a) $f(6) = 5$ (b) $f(6) < 5$
 (c) $f(6) < 8$ (d) $f(6) \geq 8$
26. If f is a real-valued differentiable function satisfying $|f(x) - f(y)| \leq (x - y)^2$, $x, y \in R$ and $f(0) = 0$, then $f(1)$ equals :
 (a) 1 (b) 2
 (c) 0 (d) -1
27. If x is so small that x^3 and higher powers of x may be neglected, then

$$\frac{(1+x)^{3/2} - \left(1 + \frac{1}{2}x\right)^3}{(1-x)^{1/2}}$$
 may be approximated as :
 (a) $\frac{x}{2} - \frac{3}{8}x^2$ (b) $-\frac{3}{8}x^2$
 (c) $3x + \frac{3}{8}x^2$ (d) $1 - \frac{3}{8}x^2$

28. If $x = \sum_{n=0}^{\infty} a^n$, $y = \sum_{n=0}^{\infty} b^n$, $z = \sum_{n=0}^{\infty} c^n$ where a, b, c are in AP and $|a| < 1, |b| < 1, |c| < 1$, then x, y, z are in :
 (a) HP
 (b) Arithmetico-Geometric Progression
 (c) AP
 (d) GP

29. In a triangle ABC , let $\angle C = \pi/2$, if r is the inradius and R is the circumradius of the triangle ABC , then $2(r + R)$ equals :
 (a) $c + a$ (b) $a + b + c$
 (c) $a + b$ (d) $b + c$

30. If $\cos^{-1} x - \cos^{-1} \frac{y}{2} = \alpha$, then $4x^2 - 4xy \cos \alpha + y^2$ is equal to :
 (a) $-4 \sin^2 \alpha$ (b) $4 \sin^2 \alpha$
 (c) 4 (d) $2 \sin 2\alpha$

31. If in a ΔABC , the altitudes from the vertices A, B, C on opposite sides are in HP, then $\sin A, \sin B, \sin C$ are in :
 (a) HP
 (b) Arithmetico-Geometric Progression
 (c) AP
 (d) GP

32. The normal to the curve $x = a(\cos \theta + \theta \sin \theta)$, $y = a(\sin \theta - \theta \cos \theta)$ at any point 'O' is such that :
 (a) it is at a constant distance from the origin
 (b) it passes through $(a\pi/2, -a)$
 (c) it makes angle $\pi/2 + \theta$ with the x -axis
 (d) it passes through the origin

33. A function is matched below against an interval where it is supposed to be increasing. Which of the following pairs is incorrectly matched ?

Interval	Function
(a) $(-\infty, -4]$	$x^3 + 6x^2 + 6$
(b) $(-\infty, \frac{1}{3}]$	$3x^2 - 2x + 1$
(c) $[2, \infty)$	$2x^3 - 3x^2 - 12x + 6$
(d) $(-\infty, \infty)$	$x^3 - 3x^2 + 3x + 3$

34. Let α and β be the distinct roots of $ax^2 + bx + c = 0$, then

$\lim_{x \rightarrow \alpha} \frac{1 - \cos(ax^2 + bx + c)}{(x - \alpha)^2}$ is equal to :

(a) $\frac{1}{2}(\alpha - \beta)^2$ (b) $-\frac{a^2}{2}(\alpha - \beta)^2$
 (c) 0 (d) $\frac{a^2}{2}(\alpha - \beta)^2$

35. If $x \frac{dy}{dx} = y(\log y - \log x + 1)$, then the solution of the equation is :

(a) $\log\left(\frac{x}{y}\right) = cy$ (b) $\log\left(\frac{y}{x}\right) = cx$
 (c) $x \log\left(\frac{y}{x}\right) = cy$ (d) $y \log\left(\frac{x}{y}\right) = cx$

36. The line parallel to the x -axis and passing through the intersection of the lines $ax + 2by + 3b = 0$ and $bx - 2ay - 3a = 0$, where $(a, b) \neq (0, 0)$ is :

- (a) above the x -axis at a distance of $(2/3)$ from it.
 (b) above the x -axis at a distance of $(3/2)$ from it.
 (c) below the x -axis at a distance of $(2/3)$ from it.
 (d) below the x -axis at a distance of $(3/2)$ from it.

37. A spherical iron ball 10 cm in radius is coated with a layer of ice of uniform thickness that melts at a rate of $50 \text{ cm}^3/\text{min}$. When the thickness of ice is 15 cm, then the rate at which the thickness of ice decreases, is :

(a) $\frac{5}{6\pi} \text{ cm/min}$ (b) $\frac{1}{54\pi} \text{ cm/min}$
 (c) $\frac{1}{18\pi} \text{ cm/min}$ (d) $\frac{1}{36\pi} \text{ cm/min}$

38. $\int \left\{ \frac{(\log x - 1)}{1 + (\log x)^2} \right\}^2 dx$ is equal to :

(a) $\frac{x}{(\log x)^2 + 1} + c$ (b) $\frac{xe^x}{1 + x^2} + c$
 (c) $\frac{x}{x^2 + 1} + c$ (d) $\frac{\log x}{(\log x)^2 + 1} + c$

39. Let $f: R \rightarrow R$ be a differentiable function having $f(2) = 6$, $f'(2) = \left(\frac{1}{48}\right)$.

Then $\lim_{x \rightarrow 2} \int_6^{f(x)} \frac{4t^3}{-x-2} dt$ equals :

- (a) 18 (b) 12
 (c) 36 (d) 24

40. Let $f(x)$ be a non-negative continuous function such that the area bounded by the curve $y = f(x)$, x -axis and the ordinates $x = \pi/4$ and $x = \beta > \pi/4$ is

$\left(\beta \sin \beta + \frac{\pi}{4} \cos \beta + \sqrt{2} \beta \right)$. Then $f\left(\frac{\pi}{2}\right)$ is :

- (a) $\left(1 - \frac{\pi}{4} + \sqrt{2}\right)$ (b) $\left(1 - \frac{\pi}{4} - \sqrt{2}\right)$
 (c) $\left(\frac{\pi}{4} - \sqrt{2} + 1\right)$ (d) $\left(\frac{\pi}{4} + \sqrt{2} - 1\right)$
41. If $I_1 = \int_0^1 2^{x^2} dx$, $I_2 = \int_0^1 2^{x^3} dx$,
 $I_3 = \int_1^2 2^{x^2} dx$ and $I_4 = \int_1^2 2^{x^3} dx$, then :
 (a) $I_3 > I_4$ (b) $I_3 = I_4$
 (c) $I_1 > I_2$ (d) $I_2 > I_1$
42. The area enclosed between the curve $y = \log_e(x + e)$ and the co-ordinate axes is :
 (a) 4 (b) 3
 (c) 2 (d) 1
43. The parabolas $y^2 = 4x$ and $x^2 = 4y$ divide the square region bounded by the lines $x = 4$, $y = 4$ and the co-ordinate axes. If S_1, S_2, S_3 are respectively the areas of these parts numbered from top to bottom, then $S_1 : S_2 : S_3$ is :
 (a) 1 : 1 : 1 (b) 2 : 1 : 2
 (c) 1 : 2 : 3 (d) 1 : 2 : 1
44. If the plane $2ax - 3ay + 4az + 6 = 0$ passes through the mid point of the line joining the centres of the spheres $x^2 + y^2 + z^2 + 6x - 8y - 2z = 13$ and $x^2 + y^2 + z^2 - 10x + 4y - 2z = 8$, then a equals :
 (a) 2 (b) -2
 (c) 1 (d) -1
45. The distance between the line $\vec{r} = 2\hat{i} - 2\hat{j} + 3\hat{k} + \lambda(\hat{i} - \hat{j} + 4\hat{k})$ and the plane $\vec{r} \cdot (\hat{i} + 5\hat{j} + \hat{k}) = 5$ is :
 (a) $\frac{10}{3}$ (b) $\frac{3}{10}$
 (c) $\frac{10}{3\sqrt{3}}$ (d) $\frac{10}{9}$
46. For any vector \vec{a} , the value of $(\vec{a} \times \hat{i})^2 + (\vec{a} \times \hat{j})^2 + (\vec{a} \times \hat{k})^2$ is equal to :
 (a) $4\vec{a}^2$ (b) $2\vec{a}^2$
 (c) \vec{a}^2 (d) $3\vec{a}^2$
47. If non-zero numbers a, b, c are in HP, then the straight line $\frac{x}{a} + \frac{y}{b} + \frac{z}{c} = 0$ always passes through a fixed point. That point is :
 (a) $\left(1, -\frac{1}{2}\right)$ (b) $(1, -2)$
 (c) $(-1, -2)$ (d) $(-1, 2)$
48. If a vertex of a triangle is $(1, 1)$ and the mid points of two sides through this vertex are $(-1, 2)$ and $(3, 2)$, then the centroid of the triangle is :
 (a) $\left(\frac{1}{3}, \frac{7}{3}\right)$ (b) $\left(1, \frac{7}{3}\right)$
 (c) $\left(-\frac{1}{3}, \frac{7}{3}\right)$ (d) $\left(-1, \frac{7}{3}\right)$
49. If the circles $x^2 + y^2 + 2ax + cy + a = 0$ and $x^2 + y^2 - 3ax + dy - 1 = 0$ intersect in two distinct points P and Q , then the line $5x + by - a = 0$ passes through P and Q for :
 (a) exactly two values of a
 (b) infinitely many values of a
 (c) no value of a
 (d) exactly one value of a
50. A circle touches the x -axis and also touches the circle with centre at $(0, 3)$ and radius 2. The locus of the centre of the circle is :
 (a) a parabola (b) a hyperbola
 (c) a circle (d) an ellipse
51. If a circle passes through the point (a, b) and cuts the circle $x^2 + y^2 = p^2$ orthogonally, then the equation of the locus of its centre is :
 (a) $2ax + 2by - (a^2 + b^2 + p^2) = 0$
 (b) $x^2 + y^2 - 2ax - 3by + (a^2 - b^2 - p^2) = 0$
 (c) $2ax + 2by - (a^2 - b^2 + p^2) = 0$
 (d) $x^2 + y^2 - 3ax - 4by + (a^2 + b^2 - p^2) = 0$
52. An ellipse has OB as semi minor axis, F and F' its foci and the angle FBF' is a right angle. Then the eccentricity of the ellipse is :
 (a) $\frac{1}{\sqrt{3}}$ (b) $\frac{1}{4}$
 (c) $\frac{1}{2}$ (d) $\frac{1}{\sqrt{2}}$
53. The locus of a point $P(\alpha, \beta)$ moving under the condition that the line $y = \alpha x + \beta$ is a tangent to the hyperbola $\frac{x^2}{a^2} - \frac{y^2}{b^2} = 1$ is :
 (a) a hyperbola (b) a parabola
 (c) a circle (d) an ellipse
54. If the angle θ between the line $\frac{x+1}{1} = \frac{y-1}{2} = \frac{z-2}{2}$ and the plane $2x - y + \sqrt{\lambda}z + 4 = 0$ is such that $\sin \theta = \frac{1}{3}$. The value of λ is :
 (a) $-\frac{4}{3}$ (b) $\frac{3}{4}$
 (c) $-\frac{3}{5}$ (d) $\frac{5}{3}$

55. The angle between the lines $2x = 3y = -z$ and $6x = -y = -4z$ is :
 (a) 30° (b) 45°
 (c) 90° (d) 0°
56. Let A and B be two events such that $P(\overline{A \cup B}) = \frac{1}{6}$, $P(A \cap B) = \frac{1}{4}$ and $P(\overline{A}) = \frac{1}{4}$, where \overline{A} stands for complement of event A . Then events A and B are :
 (a) mutually exclusive and independent
 (b) independent but not equally likely
 (c) equally likely but not independent
 (d) equally likely and mutually exclusive
57. Three houses are available in a locality. Three persons apply for the houses. Each applies for one house without consulting others. The probability that all the three apply for the same house, is :
 (a) $\frac{7}{9}$ (b) $\frac{8}{9}$
 (c) $\frac{1}{9}$ (d) $\frac{2}{9}$
58. A random variable X has Poisson distribution with mean 2. Then $P(X > 1.5)$ equals :
 (a) $\frac{3}{e^2}$ (b) $1 - \frac{3}{e^2}$
 (c) 0 (d) $\frac{2}{e^2}$
59. Two points A and B move from rest along a straight line with constant acceleration f and f' respectively. If A takes m sec more than B and describes ' n ' unit more than B in acquiring the same speed, then :
 (a) $(f' - f)n = \frac{1}{2}ff'm^2$
 (b) $\frac{1}{2}(f + f')m = ff'n^2$
 (c) $(f + f')m^2 = ff'n$
 (d) $(f - f')m^2 = ff'n$
60. A lizard, at an initial distance of 21 cm behind an insect, moves from rest with an acceleration of 2 cm/s^2 and pursues the insect which is crawling uniformly along a straight line at a speed of 20 cm/s. Then the lizard will catch the insect after :
 (a) 24 s (b) 21 s
 (c) 1 s (d) 20 s
61. The resultant R of two forces acting on a particle is at right angles to one of them and its magnitude is one third of the other force. The ratio of larger force to smaller one is :
 (a) $3 : 2\sqrt{2}$ (b) $3 : 2$
 (c) $3 : \sqrt{2}$ (d) $2 : 1$
62. Let $\vec{a} = \hat{i} - \hat{k}$, $\vec{b} = x\hat{i} + \hat{j} + (1-x)\hat{k}$ and $\vec{c} = y\hat{i} + x\hat{j} + (1+x-y)\hat{k}$. Then $[\vec{a} \ \vec{b} \ \vec{c}]$ depends on :
 (a) neither x nor y (b) both x and y
 (c) only x (d) only y
63. Let a , b and c be distinct non-negative numbers. If the vectors $a\hat{i} + a\hat{j} + c\hat{k}$, $\hat{i} + \hat{k}$ and $c\hat{i} + c\hat{j} + b\hat{k}$ lie in a plane, then c is :
 (a) the harmonic mean of a and b
 (b) equal to zero
 (c) the arithmetic mean of a and b
 (d) the geometric mean of a and b
64. If \vec{a} , \vec{b} , \vec{c} are non-coplanar vectors and λ is a real number, then
 $[\lambda(\vec{a} + \vec{b}) \ \lambda^2 \vec{b} \ \lambda \vec{c}] = [\vec{a} \ \vec{b} + \vec{c} \ \vec{b}]$
 for :
 (a) exactly two values of λ
 (b) exactly three values of λ
 (c) no value of λ
 (d) exactly one value of λ
65. A and B are two like parallel forces. A couple of moment H lies in the plane of A and B and is contained with them. The resultant of A and B after combining is displaced through a distance :
 (a) $\frac{H}{A-B}$ (b) $\frac{H}{2(A+B)}$
 (c) $\frac{H}{A+B}$ (d) $\frac{2H}{A-B}$
66. The sum of the series $1 + \frac{1}{4 \cdot 2!} + \frac{1}{16 \cdot 4!} + \frac{1}{64 \cdot 6!} + \dots$ is :
 (a) $\frac{e+1}{2\sqrt{e}}$ (b) $\frac{e-1}{2\sqrt{e}}$
 (c) $\frac{e+1}{\sqrt{e}}$ (d) $\frac{e-1}{\sqrt{e}}$
67. Let x_1, x_2, \dots, x_n be n observations such that $\sum x_i^2 = 400$ and $\sum x_i = 80$. Then a possible value of n among the following is :
 (a) 12 (b) 9
 (c) 18 (d) 15
68. A particle is projected from a point O with velocity u at an angle of 60° with the horizontal. When it is moving in a direction at right angle to its direction at O , then its velocity is given by :

- (a) $\frac{u}{\sqrt{3}}$ (b) $\frac{2u}{3}$
 (c) $\frac{u}{2}$ (d) $\frac{u}{3}$

69. If both the roots of the quadratic equation $x^2 - 2kx + k^2 + k - 5 = 0$ are less than 5, then k lies in the interval :

- (a) [4, 5] (b) $(-\infty, 4)$
 (c) $(6, \infty)$ (d) (5, 6]

70. If $a_1, a_2, a_3, \dots, a_p, \dots$ are in GP, then the determinant

$$\Delta = \begin{vmatrix} \log a_n & \log a_{n-1} & \log a_{n+2} \\ \log a_{n+3} & \log a_{n+4} & \log a_{n-5} \\ \log a_{n+6} & \log a_{n+7} & \log a_{n+8} \end{vmatrix}$$

is equal to :

- (a) 2 (b) 4
 (c) 0 (d) 1

71. A real valued function $f(x)$ satisfies the functional equation

$$f(x-y) = f(x)f(y) - f(a-x)f(a+y)$$

where a is a given constant and $f(0) = 1$, $f(2a-x)$ is equal to :

- (a) $f(-x)$ (b) $f(a) + f(a-x)$
 (c) $f(x)$ (d) $-f(x)$

72. If the equation

$$a_n x^n + a_{n-1} x^{n-1} + \dots + a_1 x = 0,$$

$a_1 \neq 0, n \geq 2$, has a positive root $x = \alpha$, then the equation

$na_n x^{n-1} + (n-1)a_{n-1} x^{n-2} + \dots + a_1 = 0$ has a positive root, which is :

- (a) equal to α
 (b) greater than or equal to α
 (c) smaller than α
 (d) greater than α

73. The value of $\int_{-\pi}^{\pi} \frac{\cos^2 x}{1 + a^x} dx, a > 0$, is :

- (a) 2π (b) $\frac{\pi}{a}$
 (c) $\frac{\pi}{2}$ (d) $a\pi$

74. The plane $x + 2y - z = 4$ cuts the sphere $x^2 + y^2 + z^2 - x + z - 2 = 0$ in a circle of radius :

- (a) $\sqrt{2}$ (b) 2
 (c) 1 (d) 3

75. If the pair of lines $ax^2 + 2(a+b)xy + by^2 = 0$ lie along diameters of a circle and divide the circle into four sectors such that the area of one of the sectors is thrice the area of another sector, then :

- (a) $3a^2 + 2ab + 3b^2 = 0$
 (b) $3a^2 + 10ab + 3b^2 = 0$
 (c) $3a^2 - 2ab + 3b^2 = 0$
 (d) $3a^2 - 10ab + 3b^2 = 0$

ANSWERS

⇒ PHYSICS AND CHEMISTRY

1. (d)	2. (d)	3. (a)	4. (c)	5. (d)	6. (c)	7. (c)	8. (*)
9. (d)	10. (c)	11. (d)	12. (a)	13. (b)	14. (d)	15. (d)	16. (a)
17. (c)	18. (d)	19. (b)	20. (c)	21. (a)	22. (b)	23. (a,d)	24. (c)
25. (c)	26. (d)	27. (b)	28. (d)	29. (c)	30. (b)	31. (c)	32. (a)
33. (c)	34. (c)	35. (a)	36. (b)	37. (d)	38. (a)	39. (b)	40. (a)
41. (a)	42. (a)	43. (c)	44. (c)	45. (c)	46. (b)	47. (d)	48. (b)
49. (b)	50. (b)	51. (d)	52. (d)	53. (a)	54. (a)	55. (a)	56. (d)
57. (a)	58. (b)	59. (a)	60. (c)	61. (b)	62. (a)	63. (d)	64. (c)
65. (c)	66. (b)	67. (c)	68. (c)	69. (a)	70. (c)	71. (a)	72. (d)
73. (d)	74. (a)	75. (c)	76. (d)	77. (c)	78. (a)	79. (c)	80. (b)
81. (c)	82. (d)	83. (d)	84. (b)	85. (b)	86. (a)	87. (a)	88. (d)
89. (d)	90. (a)	91. (b)	92. (c)	93. (d)	94. (c)	95. (d)	96. (a)
97. (a)	98. (d)	99. (b)	100. (b)	101. (b)	102. (b)	103. (a)	104. (c)
105. (d)	106. (d)	107. (a)	108. (c)	109. (c)	110. (a)	111. (b)	112. (c)
113. (d)	114. (c)	115. (a)	116. (d)	117. (b)	118. (c)	119. (c)	120. (b)
121. (c)	122. (b)	123. (a)	124. (b)	125. (b)	126. (c)	127. (b)	128. (a)
129. (a)	130. (c)	131. (c)	132. (b)	133. (b)	134. (c)	135. (d)	136. (c)
137. (c)	138. (c)	139. (b)	140. (d)	141. (d)	142. (a)	143. (d)	144. (d)
145. (c)	146. (c)	147. (d)	148. (a)	149. (b)	150. (c)		

* No option is matching

⇒ MATHEMATICS

1. (d)	2. (d)	3. (a)	4. (d)	5. (a)	6. (b)	7. (a)	8. (d)
9. (b)	10. (b)	11. (b)	12. (c)	13. (d)	14. (a)	15. (d)	16. (a)
17. (a)	18. (b)	19. (b)	20. (a)	21. (d)	22. (d)	23. (a)	24. (b)
25. (d)	26. (c)	27. (b)	28. (a)	29. (c)	30. (b)	31. (c)	32. (a,c)
33. (b)	34. (d)	35. (b)	36. (d)	37. (c)	38. (a)	39. (a)	40. (a)
41. (c)	42. (d)	43. (a)	44. (b)	45. (c)	46. (b)	47. (b)	48. (b)
49. (c)	50. (a)	51. (a)	52. (d)	53. (a)	54. (d)	55. (c)	56. (b)
57. (c)	58. (b)	59. (a)	60. (b)	61. (a)	62. (a)	63. (d)	64. (c)
65. (c)	66. (a)	67. (c)	68. (a)	69. (b)	70. (c)	71. (d)	72. (c)
73. (c)	74. (c)	75. (a)					

HINTS & SOLUTIONS

Physics

1. A projectile can have same range if angles of projection are complementary i.e., θ and $(90^\circ - \theta)$. Thus, in both cases :

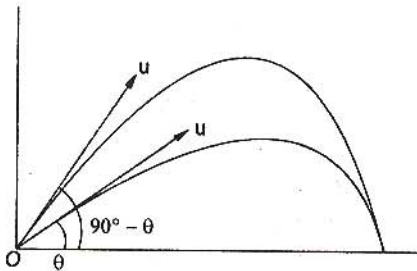

$$t_1 = \frac{2u \sin \theta}{g} \quad \dots(i)$$

$$t_2 = \frac{2u \sin (90^\circ - \theta)}{g} \\ = \frac{2u \cos \theta}{g} \quad \dots(ii)$$

From Eqs. (i) and (ii)

$$t_1 t_2 = \frac{4u^2 \sin \theta \cos \theta}{g^2}$$

$$t_1 t_2 = \frac{2u^2 \sin 2\theta}{g^2} \\ = \frac{2u^2 \sin 2\theta}{g \cdot g}$$

$$\therefore t_1 t_2 = \frac{2R}{g} \quad \left(\because R = \frac{u^2 \sin 2\theta}{g} \right)$$

Hence, $t_1 t_2 \propto R$

2. Since ω is constant, v would also be constant. So, no net force or torque is acting on ring. The force experienced by any particle is only along radial direction, or we can say the centripetal force.

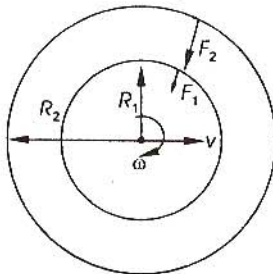

The force experienced by inner part, $F_1 = m\omega^2 R_1$ and the force experienced by outer part, $F_2 = m\omega^2 R_2$

$$\frac{F_1}{F_2} = \frac{R_1}{R_2}$$

3. When friction is absent

$$a_1 = g \sin \theta$$

$$\therefore s_1 = \frac{1}{2} a_1 t_1^2 \quad \dots(i)$$

When friction is present

$$a_2 = g \sin \theta - \mu_k g \cos \theta$$

$$\therefore s_2 = \frac{1}{2} a_2 t_2^2 \quad \dots(ii)$$

From Eqs. (i) and (ii)

$$\frac{1}{2} a_1 t_1^2 = \frac{1}{2} a_2 t_2^2$$

$$\text{or } a_1 t_1^2 = a_2 (n t_1)^2 \quad (\because t_2 = n t_1)$$

$$\text{or } a_1 = n^2 a_2$$

$$\text{or } \frac{a_2}{a_1} = \frac{g \sin \theta - \mu_k g \cos \theta}{g \sin \theta} = \frac{1}{n^2}$$

$$\text{or } \frac{g \sin 45^\circ - \mu_k g \cos 45^\circ}{g \sin 45^\circ} = \frac{1}{n^2}$$

$$\text{or } 1 - \mu_k = \frac{1}{n^2}$$

$$\text{or } \mu_k = 1 - \frac{1}{n^2}$$

4. According to work-energy theorem,

$$W = \Delta K = 0$$

(\because Initial and final speeds are zero)

\therefore Work done by friction + work done by gravity

$$= 0 \\ - \mu mg \cos \phi \cdot \frac{l}{2} + mgl \sin \phi = 0$$

$$\text{or } \frac{\mu}{2} \cos \phi = \sin \phi$$

$$\therefore \mu = 2 \tan \phi$$

5. According to work-energy theorem,

$$W = \Delta K$$

$$\text{Case I : } -F \times 3 = \frac{1}{2} m \left(\frac{v_0}{2} \right)^2 - \frac{1}{2} m v_0^2$$

where, F is resistive force and v_0 is initial speed.

Case II : Let, the further distance travelled by the bullet before coming to rest is s .

$$\therefore -F(3+s) = K_f - K_i = -\frac{1}{2}mv_0^2$$

$$\text{or } -\frac{1}{8}mv_0^2(3+s) = -\frac{1}{2}mv_0^2$$

$$\text{or } \frac{1}{4}(3+s) = 1$$

$$\text{or } \frac{3}{4} + \frac{s}{4} = 1$$

$$\therefore s = 1 \text{ cm}$$

6. $I = mr^2$

$$\therefore [I] = [ML^2]$$

and $\vec{\tau}$ = moment of force = $\vec{r} \times \vec{F}$

$$\therefore [\vec{\tau}] = [L][MLT^{-2}] = [ML^2T^{-2}]$$

7. Given $t = ax^2 + bx$

Differentiating w.r.t. t

$$\frac{dt}{dt} = 2ax \frac{dx}{dt} + b \frac{dx}{dt}$$

$$v = \frac{dx}{dt} = \frac{1}{(2ax + b)}$$

Again differentiating w.r.t. t

$$\frac{d^2x}{dt^2} = \frac{-2a}{(2ax + b)^2} \cdot \frac{dx}{dt}$$

$$\therefore f = \frac{d^2x}{dt^2} = \frac{-1}{(2ax + b)^2} \cdot \frac{2a}{(2ax + b)}$$

$$\text{or } f = \frac{-2a}{(2ax + b)^3}$$

$$\therefore f = -2av^3$$

8. The velocity time graph for the given situation can be drawn as below. Magnitudes of slope of $OA = f$

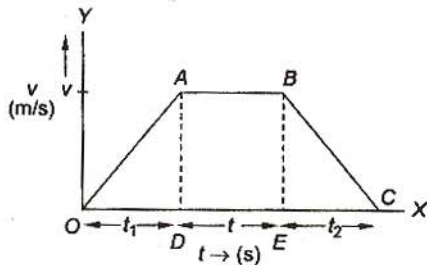

and slope of $BC = \frac{f}{2}$

$$v = ft_1 = \frac{f}{2}t_2$$

$$\therefore t_2 = 2t_1$$

In graph area of ΔOAD gives

$$\text{distances, } S = \frac{1}{2}ft_1^2 \quad \dots(i)$$

Area of rectangle $ABED$ gives distance travelled in time t .

$$S_2 = (ft_1)t$$

$$\text{Distance travelled in time } t_2$$

$$= S_3 = \frac{1}{2} \frac{f}{2} (2t_1)^2$$

Thus, $S_1 + S_2 + S_3 = 15S$

$$S + (ft_1)t + ft_1^2 = 15S$$

$$S + (ft_1)t + 2S = 15S \quad \left(S = \frac{1}{2}ft_1^2 \right)$$

$$(ft_1)t = 12S \quad \dots(ii)$$

From Eqs. (i) and (ii), we have

$$\frac{12S}{S} = \frac{(ft_1)t}{\frac{1}{2}(ft_1)t_1}$$

$$\therefore t_1 = \frac{t}{6}$$

From Eq. (i), we get

$$\therefore S = \frac{1}{2}f(t_1)^2$$

$$\therefore S = \frac{1}{2}f\left(\frac{t}{6}\right)^2 = \frac{1}{72}ft^2$$

Hence, none of the given options is correct.

9. $\vec{v}_1 = +5\hat{i}$

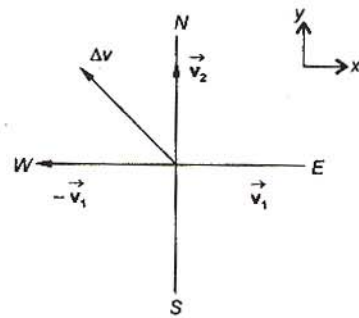

$$\vec{v}_2 = 5\hat{j}$$

$$\Delta \vec{v} = \vec{v}_2 - \vec{v}_1 = 5\hat{j} - 5\hat{i}$$

$$|\Delta \vec{v}| = 5\sqrt{2}$$

$$a = \frac{|\Delta \vec{v}|}{t} = \frac{5\sqrt{2}}{10} = \frac{1}{\sqrt{2}} \text{ ms}^{-2}$$

For direction,

$$\therefore \tan \alpha = -\frac{5}{5} = -1$$

Average acceleration is $\frac{1}{\sqrt{2}} \text{ ms}^{-2}$ towards north-west.

10. Parachute bails out at height H from ground. Velocity at A

$$\begin{aligned} v &= \sqrt{2gh} \\ &= \sqrt{2 \times 9.8 \times 50} \\ &= \sqrt{980} \text{ m/s} \end{aligned}$$

The velocity at ground $v_1 = 3 \text{ m/s}$ (given)
Acceleration $= -2 \text{ m/s}^2$ (given)

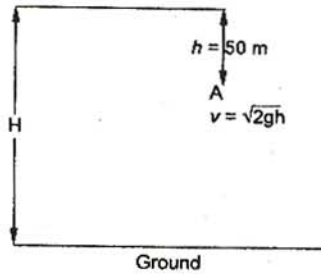

$$\begin{aligned} H - h &= \frac{v^2 - v_1^2}{2 \times 2} \\ &= \frac{980 - 9}{4} \\ &= \frac{971}{4} = 242.75 \end{aligned}$$

$$\begin{aligned} H &= 242.75 + h \\ &= 242.75 + 50 \approx 293 \text{ m} \end{aligned}$$

11. In the frame of wedge, the force diagram of block is shown in figure. From free body diagram of wedge,

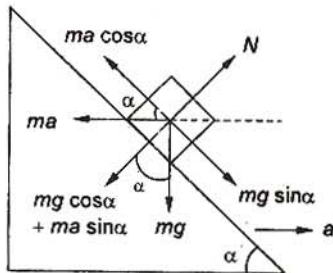

For block to remain stationary,
 $ma \cos \alpha = mg \sin \alpha$
 $a = g \tan \alpha$

12. According to conservation of energy,

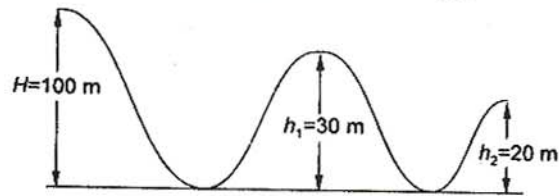

$$mgH = \frac{1}{2}mv^2 + mgh_2$$

$$\text{or } mg(H - h_2) = \frac{1}{2}mv^2$$

$$\text{or } v = \sqrt{2g(100 - 20)}$$

$$v = \sqrt{2 \times 10 \times 80} = 40 \text{ m/s}$$

13. Since, the acceleration of centre of mass in both the cases is same equal to g . So the centre of mass of the bodies B and C taken together does not shift compared to that of body A .
14. The mass of complete (circular) disc is

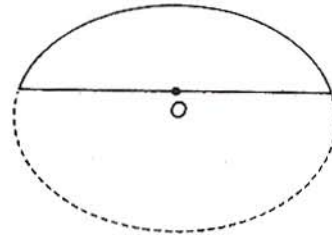

$$M + M = 2M$$

The moment of inertia of disc about the given axis is

$$\begin{aligned} I &= \frac{2Mr^2}{2} \\ &= Mr^2 \end{aligned}$$

Let, the moment of inertia of semicircular disc is I_1 . The disc may be assumed as combination of two semicircular parts.

Thus, $I_1 = I - I_1$

$$\therefore I_1 = \frac{I}{2} = \frac{Mr^2}{2}$$

15. Given : $m = 0.3 \text{ kg}$, $x = 20 \text{ cm}$, and

$$k = 15 \text{ N/m}$$

$$F = -kx \quad \dots(i)$$

$$\text{and } F = ma \quad \dots(ii)$$

$$\therefore ma = -kx$$

$$\text{or } a = -\frac{15}{0.3} \times 20 \times 10^{-2}$$

$$a = -\frac{15}{3} \times 2 = -10 \text{ m/s}^2$$

\therefore Initial acceleration $a = 10 \text{ m/s}^2$

16. Momentum would be maximum when KE would be maximum and this is the case when total elastic PE is converted to KE.

According to conservation of energy

$$\begin{aligned} \frac{1}{2} k L^2 &= \frac{1}{2} M v^2 \\ \Rightarrow k L^2 &= \frac{(M v)^2}{M} \\ M k L^2 &= p^2 \quad (p = Mv) \\ \therefore p &= L \sqrt{Mk} \end{aligned}$$

17. In x-direction

$$\begin{aligned} m u_1 + 0 &= 0 + m v_x \\ \Rightarrow m v &= m v_x \\ \Rightarrow v_x &= v \end{aligned}$$

In y-direction

$$\begin{aligned} 0 + 0 &= m \left(\frac{v}{\sqrt{3}} \right) - m v_y \\ v_y &= \frac{v}{\sqrt{3}} \end{aligned}$$

∴ Velocity of second mass after collision

$$\begin{aligned} v' &= \sqrt{\left(\frac{v}{\sqrt{3}} \right)^2 + v^2} = \sqrt{\frac{4}{3}} v \\ \therefore v' &= \frac{2}{\sqrt{3}} v \end{aligned}$$

18. Water fills the tube entirely in gravity less condition.
19. Energy stored in wire

$$= \frac{1}{2} \text{ stress} \times \text{strain} \times \text{volume}$$

$$\text{and Young's modulus} = \frac{\text{stress}}{\text{strain}}$$

$$\Rightarrow \text{strain} = \frac{S}{Y}$$

$$\frac{\text{Energy stored in wire}}{\text{Volume}} = \frac{1}{2} \times \text{stress} \times \text{strain}$$

$$= \frac{1}{2} S \times \frac{S}{Y} = \frac{S^2}{2Y}$$

20. $g = \frac{GM}{R^2}; M = \left(\frac{4}{3} \pi R^3 \right) \rho$

$$\therefore g = \frac{4G}{3} \frac{\pi R^3}{R^2} \rho$$

$$\Rightarrow g = \left(\frac{4G\pi R}{3} \right) \rho$$

(ρ = average density)

$$\Rightarrow g \propto \rho \text{ or } \rho \propto g$$

21. $F = ma = \frac{mv}{T} \quad \left(\because a = \frac{v-0}{T} \right)$

$$\begin{aligned} \text{Instantaneous power} &= Fv \\ &= mav \end{aligned}$$

$$\begin{aligned} &= \frac{mv}{T} \cdot at = \frac{mv}{T} \cdot \frac{v}{F} \cdot t \\ &= \frac{mv^2}{T^2} t \end{aligned}$$

22. $s = \frac{v^2}{2\mu_k g} = \frac{100 \times 100}{2 \times 0.5 \times 10}$
 $= \frac{100 \times 100}{5 \times 2} = 1000 \text{ m}$

23. Statements (a) and (d) are wrong. Concept of entropy is associated with second law of thermodynamics.

24. For pure translatory motion, net torque about centre of mass should be zero.

Thus, \vec{F} is applied at centre of mass of system.

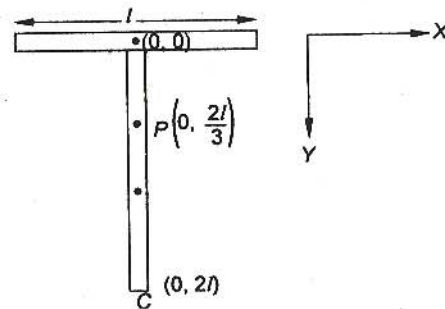

$$OP = \frac{m_1 \times 0 + m_2 \times l}{m_1 + m_2}$$

where, m_1 and m_2 are masses of horizontal and vertical section of the object. Assuming object is uniform,

$$m_2 = 2m_1 \Rightarrow OP = \frac{2l}{3}$$

$$\begin{aligned} \therefore PC &= \left(l - \frac{2l}{3} + l \right) \\ &= \left(2l - \frac{2l}{3} \right) = \frac{4l}{3} \end{aligned}$$

25. $g_h = g \left(1 - \frac{2h}{R} \right) \quad \dots(i)$

$$g_d = g \left(1 - \frac{d}{R} \right) \quad \dots(ii)$$

From Eqs. (i) and (ii),

$$g \left(1 - \frac{2h}{R} \right) = g \left(1 - \frac{d}{R} \right)$$

$$\Rightarrow 2h = d$$

26. $U_i = -\frac{GMm}{r}$

$$U_i = -\frac{6.67 \times 10^{-11} \times 100 \times 10^{-2}}{0.1}$$

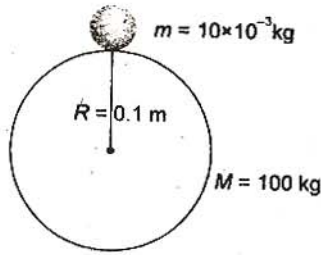

$$U_i = -\frac{6.67 \times 10^{-11}}{0.1}$$

$$= -6.67 \times 10^{-10} \text{ J}$$

We know

$$\therefore W = \Delta U$$

$$= U_f - U_i \quad (\because U_f = 0)$$

$$\therefore W = -U_i = 6.67 \times 10^{-10} \text{ J}$$

$$27. C_v = \frac{n_1 C_{v1} + n_2 C_{v2}}{n_1 + n_2}$$

$$\text{For helium, } n_1 = \frac{16}{4} = 4 \text{ and } \gamma_1 = \frac{5}{3}$$

$$\text{For oxygen, } n_2 = \frac{16}{32} = \frac{1}{2} \text{ and } \gamma_2 = \frac{7}{5}$$

$$C_{v1} = \frac{R}{\gamma_1 - 1}$$

$$= \frac{R}{\frac{5}{3} - 1} = \frac{3}{2} R$$

$$C_{v2} = \frac{R}{\gamma_2 - 1} = \frac{R}{\frac{7}{5} - 1} = \frac{5}{2} R$$

$$\therefore C_v = \frac{4 \times \frac{3}{2} R + \frac{1}{2} \times \frac{5}{2} R}{4 + \frac{1}{2}}$$

$$= \frac{6R + \frac{5}{4}R}{\frac{9}{2}}$$

$$= \frac{29R \times 2}{9 \times 4} = \frac{29R}{18}$$

Now,

$$C_v = \frac{R}{\gamma - 1}$$

$$\Rightarrow \gamma - 1 = \frac{R}{C_v}$$

$$\gamma = \frac{R}{C_v} + 1 = \frac{R}{\frac{29}{18}R} + 1$$

$$\Rightarrow \frac{C_p}{C_v} = \frac{18}{29} + 1$$

$$= \frac{18 + 29}{29} = 1.62$$

$$28. I' = I e^{-\mu x}$$

$$-\mu x = \log \frac{I'}{I}$$

$$-\mu \cdot 36 = \log \frac{I}{8I} \quad \dots(i)$$

$$-\mu x' = \log \frac{I}{2I} \quad \dots(ii)$$

From Eqs. (i) and (ii),

$$\frac{36}{x'} = \frac{3 \log \left(\frac{1}{2} \right)}{\log \frac{1}{2}}$$

$$\therefore x' = 12 \text{ mm}$$

$$29. E_g = h \nu$$

$$= \frac{h c}{\lambda} = \left(\frac{6.63 \times 10^{-34} \times 3 \times 10^8}{2480 \times 10^{-9} \times 1.6 \times 10^{-19}} \right) \text{ eV}$$

$$= 0.5 \text{ eV}$$

$$30. \frac{I_2}{I_1} = \frac{(r_1)^2}{(r_2)^2} \quad \left(\text{as } I \propto \frac{1}{r^2} \right)$$

$$\Rightarrow \frac{I_2}{I_1} = \frac{(1)^2}{\left(\frac{1}{2} \right)^2}$$

$$I_2 = 4 I_1$$

Now, since number of electrons emitted per second is directly proportional to intensity, so number of electrons emitted by photocathode would increase by a factor of 4.

$$31. N = N_0 (1 - e^{-\lambda t})$$

$$\Rightarrow \frac{N_0 - N}{N_0} = e^{-\lambda t}$$

$$\therefore \frac{1}{8} = e^{-\lambda t}$$

$$\Rightarrow 8 = e^{\lambda t}$$

$$\Rightarrow 3 \ln 2 = \lambda t$$

$$\Rightarrow \lambda = \frac{3 \times 0.693}{15}$$

Half-life period

$$t_{1/2} = \frac{0.693}{3 \times 0.693} \times 15$$

$$t_{1/2} = 5 \text{ min}$$

$$32. R = R_0 (A)^{1/3}$$

$$\frac{R_{Al}}{R_{Te}} = \frac{R_0 (A_{Al})^{1/3}}{R_0 (A_{Te})^{1/3}}$$

$$\frac{R_{Al}}{R_{Te}} = \frac{(A_{Al})^{1/3}}{(A_{Te})^{1/3}}$$

$$= \frac{(27)^{1/3}}{(125)^{1/3}} = \frac{3}{5}$$

$$R_{Te} = \frac{5}{3} \times 3.6$$

$$R_{Te} = 6 \text{ fermi}$$

33. According to the figure

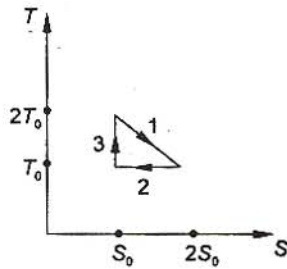

$$Q_1 = T_0 S_0 + \frac{1}{2} T_0 S_0 = \frac{3}{2} T_0 S_0$$

$$Q_2 = T_0 (2S_0 - S_0) = T_0 S_0$$

$$Q_3 = 0$$

$$\eta = \frac{W}{Q_1} = \frac{Q_1 - Q_2}{Q_1}$$

$$= 1 - \frac{Q_2}{Q_1} = 1 - \frac{2}{3}$$

$$= \frac{1}{3}$$

34. To measure the radial rate of heat flow, we have to go for integration technique as here the area of the surface through which heat will flow is not constant.

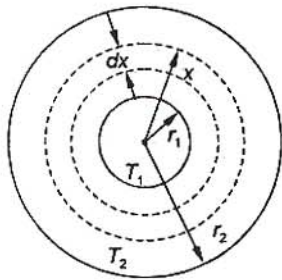

Let us consider an element (spherical shell) of thickness dx and radius x as shown in figure. Let us first find the equivalent thermal resistance between inner and outer sphere.

$$\text{Resistance of shell} = dR = \frac{dx}{K \times 4\pi x^2}$$

$$\left[\text{from } R = \frac{l}{KA} \text{ where } \right. \\ \left. K \rightarrow \text{thermal conductivity} \right]$$

$$\Rightarrow \int dR = R = \int_{r_1}^{r_2} \frac{dx}{4\pi K x^2} = \frac{1}{4\pi K} \left[\frac{1}{r_1} - \frac{1}{r_2} \right]$$

$$= \frac{r_2 - r_1}{4\pi K (r_1 r_2)}$$

Rate of heat flow = H

$$= \frac{T_1 - T_2}{R} = \frac{T_1 - T_2}{r_2 - r_1} \times 4\pi K (r_1 r_2) \propto \frac{r_1 r_2}{r_2 - r_1}$$

35. The change in internal energy does not depend upon path followed by the process. It only depends on initial and final states.

$$\text{Hence, } \Delta U_1 = \Delta U_2.$$

36. Here, $y = \sin^2 \omega t$

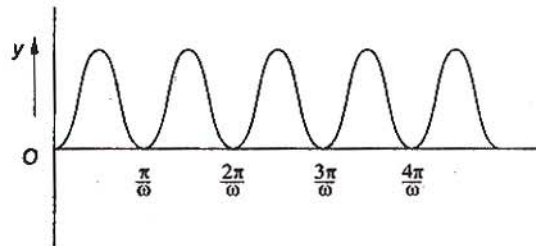

$$\frac{dy}{dt} = 2\omega \sin \omega t \cos \omega t = \omega \sin 2\omega t$$

$$\frac{d^2 y}{dt^2} = 2\omega^2 \cos 2\omega t$$

For SHM, $\frac{d^2 y}{dt^2} \propto -y$

Hence, function is not SHM, but periodic.

From the $y-t$ graph, time period is

$$T = \frac{\pi}{\omega}$$

38. Given :

$$y_1 = 0.1 \sin \left(100\pi t + \frac{\pi}{3} \right)$$

$$\therefore \frac{dy_1}{dt} = v_1 = 0.1 \times 100\pi \cos \left(100\pi t + \frac{\pi}{3} \right)$$

$$\text{or } v_1 = 10\pi \sin \left(100\pi t + \frac{\pi}{3} + \frac{\pi}{2} \right)$$

$$\text{or } v_1 = 10\pi \sin \left(100\pi t + \frac{5\pi}{6} \right)$$

$$\text{and } y_2 = 0.1 \cos \pi t$$

$$\therefore \frac{dy_2}{dt} = v_2 = -0.1 \sin \pi t = 0.1 \sin (\pi t + \pi)$$

Hence, phase difference

$$\begin{aligned}\Delta\phi &= \phi_1 - \phi_2 \\ &= \left(100\pi t + \frac{5\pi}{6}\right) - (\pi t + \pi) \\ &= \frac{5\pi}{6} - \pi \quad (\text{at } t = 0) \\ &= -\frac{\pi}{6}\end{aligned}$$

39. The situation is shown in figure.

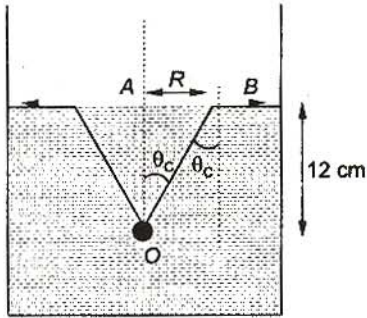

$$\begin{aligned}\sin \theta_c &= \frac{1}{\mu} \\ \tan \theta_c &= \frac{AB}{AO} \\ \therefore AB &= OA \tan \theta_c \\ \text{or } AB &= \frac{OA}{\sqrt{\mu^2 - 1}} \\ &= \frac{12}{\sqrt{\left(\frac{4}{3}\right)^2 - 1}} = \frac{36}{\sqrt{7}}\end{aligned}$$

40. We know

$$\begin{aligned}\frac{y}{D} &\geq 1.22 \frac{\lambda}{d} \\ \Rightarrow D &\leq \frac{y d}{1.22 \lambda} \\ &= \frac{10^{-3} \times 3 \times 10^{-3}}{1.22 \times 5 \times 10^{-7}} \\ &= \frac{30}{6.1} = 5 \text{ m} \\ \therefore D_{\max} &= 5 \text{ m}\end{aligned}$$

$$\begin{aligned}41. \frac{1}{f_a} &= (\mu - 1) \left(\frac{1}{R_1} - \frac{1}{R_2} \right) \\ &= (1.5 - 1) \left(\frac{1}{R_1} - \frac{1}{R_2} \right) \quad \dots(i) \\ \text{and } \frac{1}{f_m} &= \left(\frac{\mu_g - \mu_m}{\mu_m} \right) \left(\frac{1}{R_1} - \frac{1}{R_2} \right)\end{aligned}$$

$$\frac{1}{f_m} = \left(\frac{1.5}{1.6} - 1 \right) \left(\frac{1}{R_1} - \frac{1}{R_2} \right) \quad \dots(ii)$$

$$\text{Thus, } \frac{f_m}{f_a} = \frac{(1.5 - 1)}{\left(\frac{1.5}{1.6} - 1 \right)} = -8$$

$$\begin{aligned}f_m &= -8 \times f_a \\ &= -8 \times \frac{-1}{5} \quad (\because f_a = \frac{1}{p} = -\frac{1}{5} \text{ m}) \\ &= 1.6 \text{ m}\end{aligned}$$

$$\therefore P_m = \frac{\mu}{f_m} = \frac{1.6}{1.6} = 1 \text{ D}$$

$$42. E = Rhc \left[\frac{1}{n_1^2} - \frac{1}{n_2^2} \right]$$

$$\begin{aligned}E_{(4 \rightarrow 3)} &= Rhc \left[\frac{1}{3^2} - \frac{1}{4^2} \right] \\ &= Rhc \left[\frac{7}{9 \times 16} \right] = 0.05 Rhc\end{aligned}$$

$$E_{(4 \rightarrow 2)} = Rhc \left[\frac{1}{2^2} - \frac{1}{4^2} \right]$$

$$= Rhc \left[\frac{3}{16} \right] = 0.2 Rhc$$

$$\begin{aligned}E_{(2 \rightarrow 1)} &= Rhc \left[\frac{1}{(1)^2} - \frac{1}{(2)^2} \right] \\ &= Rhc \left[\frac{3}{4} \right] = 0.75 Rhc\end{aligned}$$

$$\begin{aligned}E_{(1 \rightarrow 3)} &= Rhc \left[\frac{1}{(3)^2} - \frac{1}{(1)^2} \right] \\ &= -\frac{8}{9} Rhc = -0.9 Rhc\end{aligned}$$

Thus, III transition gives most energy. I transition represents the absorption of energy.

43. We know

$$\lambda = \frac{h}{mv}$$

$$\text{and } K = \frac{1}{2} mv^2 = \frac{(mv)^2}{2m}$$

$$\Rightarrow mv = \sqrt{2mK}$$

$$\text{Thus, } \lambda = \frac{h}{\sqrt{2mK}}$$

$$\Rightarrow \lambda \propto \frac{1}{\sqrt{K}}$$

$$\therefore \frac{\lambda_2}{\lambda_1} = \frac{\sqrt{K_1}}{\sqrt{K_2}} = \frac{\sqrt{K_1}}{\sqrt{2K_1}} \quad (\because K_2 = 2K_1)$$

$$\Rightarrow \frac{\lambda_2}{\lambda_1} = \frac{1}{\sqrt{2}}$$

$$\therefore \lambda_2 = \frac{\lambda_1}{\sqrt{2}}$$

44. In common base amplifier the input signal is amplified but remain in phase with output signal.

45. Given $f = 50 \text{ Hz}$

$$\therefore T = \frac{1}{50}$$

For full wave rectifier $T_1 = \frac{T}{2} = \frac{1}{100}$

$$\therefore f_1 = 100 \text{ Hz}$$

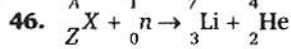

It implies that $A + 1 = 7 + 4$

$$\Rightarrow A = 10$$

and $Z + 0 = 3 + 2$

$$\Rightarrow Z = 5$$

Thus, it is boron ${}^{10}_5 \text{B}$.

47. Full scale deflection current

$$= \frac{150}{10} \text{ mA} = 15 \text{ mA}$$

Full scale deflection voltage

$$= \frac{150}{2} \text{ mV} = 75 \text{ mV}$$

Galvanometer resistance $G = \frac{75 \text{ mV}}{15 \text{ mA}} = 5 \Omega$

Required full scale deflection voltage,

$$V = 1 \times 150 = 150 \text{ V}$$

Let resistance to be connected in series is R .

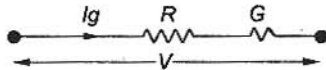

$$\Rightarrow V = I_g (R + G)$$

$$\therefore 150 = 15 \times 10^{-3} (R + 5)$$

$$\Rightarrow 10^4 = R + 5$$

$$\Rightarrow R = 10000 - 5 = 9995$$

48. We know $m = zq$

$$\Rightarrow z \propto \frac{1}{q}$$

$$\therefore \frac{z_2}{z_1} = \frac{q_1}{q_2}$$

Total charge $q = q_1 + q_2$

$$\therefore \frac{q}{q_2} = \frac{q_1}{q_2} + 1$$

$$\Rightarrow q_2 = \frac{q}{\left(1 + \frac{q_1}{q_2}\right)}$$

$$\therefore q_2 = \frac{q}{\left(1 + \frac{z_2}{z_1}\right)}$$

49. The galvanometer shows zero deflection. i.e., current through XY is zero

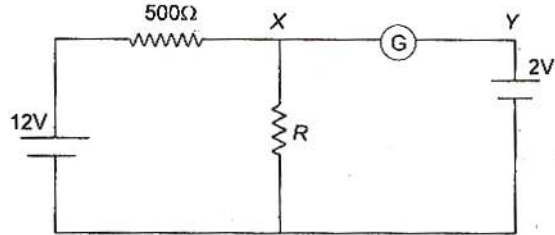

As a result potential drop across R is 2 V circuit can be redrawn as

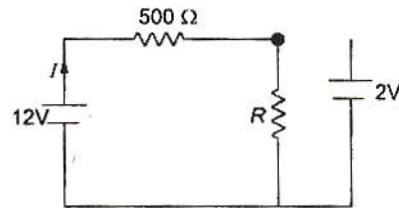

$$I = \frac{12}{500 + R}$$

Voltage across R , $V = IR$

$$\Rightarrow 2 = \frac{12}{500 + R} \times R$$

$$\Rightarrow 1000 + 2R = 12R \Rightarrow R = 100 \Omega$$

50. $R_{eq} = R_1 + R_2 + R$

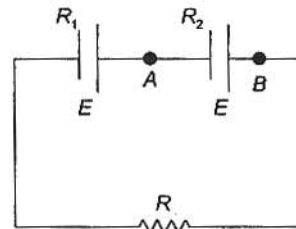

$$\therefore I = \frac{2E}{R_1 + R_2 + R}$$

According to the question,

$$-(V_A - V_B) = E - I R_2$$

$$0 = E - I R_2$$

$$E = I R_2$$

$$E = \frac{2E}{R_1 + R_2 + R} R_2$$

$$R_1 + R_2 + R = 2R_2$$

$$R = R_2 - R_1$$

51. $E = \left(\frac{1}{2}\right) CV^2$... (i)

The energy stored in capacitor is lost in form of heat energy:

$$H = ms \Delta T$$
 ... (ii)

From Eqs. (i) and (ii), we have

$$ms \Delta T = \left(\frac{1}{2}\right) CV^2$$

$$V = \sqrt{\frac{2ms\Delta T}{C}}$$

52. Relative velocity = $v - (-v) = 2v = \frac{dl}{dt}$

Now, $e = \frac{d\phi}{dt}$

$$e = \frac{Bdl}{dt} \quad \left(\frac{dl}{dt} = 2v\right)$$

Induced emf

$$e = 2Blv$$

53. $H_1 = \frac{V^2}{R} t$

$$H_2 = \frac{V^2}{R/2} t$$

$$\therefore \frac{H_2}{H_1} = 2$$

$$\Rightarrow H_2 = 2H_1$$

54. The force per unit length between the two wires is

$$\frac{F}{l} = \frac{\mu_0}{4\pi} \cdot \frac{2i^2}{d}$$

$$= \frac{\mu_0 i^2}{2\pi d}$$

The force will be attractive as current directions in both are same.

55. $I = I_0 \cos^2 \theta$

Intensity of polarized light

$$= \frac{I_0}{2}$$

\therefore Intensity of untransmitted light

$$= I_0 - \frac{I_0}{2} = \frac{I_0}{2}$$

56. Electric field due to a charged conducting sheet of surface charge density σ is given by $E = \frac{\sigma}{\epsilon_0 \epsilon_r}$

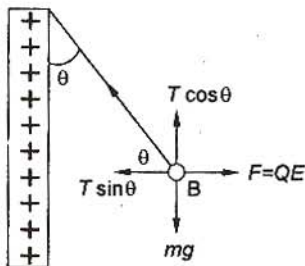

where, ϵ_0 = permittivity in vacuum and ϵ_r relative permittivity of medium.

Here, electrostatic force on B

$$QE = \frac{Q\sigma}{\epsilon_0 \epsilon_r}$$

FBD of B is shown in figure.

In equilibrium, $T \cos \theta = mg$

and $T \sin \theta = \frac{Q\sigma}{\epsilon_0 \epsilon_r}$

Thus, $\tan \theta = \frac{Q\sigma}{\epsilon_0 \epsilon_r mg}$

$$\therefore \tan \theta \propto \sigma$$

or $\sigma \propto \tan \theta$

57. Suppose that a point B, where net electric field is zero due to charges $8q$ and $-2q$.

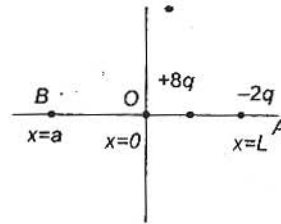

$$\vec{E}_{BO} = \frac{-1}{4\pi\epsilon_0} \cdot \frac{8q}{a^2} \hat{i}$$

$$\vec{E}_{BA} = \frac{1}{4\pi\epsilon_0} \cdot \frac{+2q}{(a+L)^2} \hat{i}$$

According to condition $\vec{E}_{BO} + \vec{E}_{BA} = 0$

$$\therefore \frac{1}{4\pi\epsilon_0} \frac{8q}{a^2} = \frac{1}{4\pi\epsilon_0} \frac{2q}{(a+L)^2}$$

$$\Rightarrow \frac{2}{a} = \frac{1}{a+L}$$

$$\Rightarrow 2a + 2L = a$$

$$\therefore 2L = -a$$

Thus, at distance $2L$ from origin, net electric field will be zero.

58. V_A = potential due to charge $+q$ on ring A + potential due to charge $-q$ on ring B

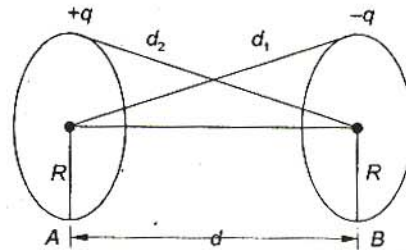

$$= \frac{1}{4\pi\epsilon_0} \left(\frac{q}{R} - \frac{q}{d_1} \right), \quad d_1 = \sqrt{R^2 + d^2}$$

$$= \frac{1}{4\pi\epsilon_0} \left(\frac{q}{R} - \frac{q}{\sqrt{R^2 + d^2}} \right) \quad \dots(i)$$

Similarly, $V_B = \frac{1}{4\pi\epsilon_0} \left(-\frac{q}{R} + \frac{q}{\sqrt{R^2 + d^2}} \right)$

Potential difference $V_A - V_B$

$$= \frac{1}{4\pi\epsilon_0} \left(\frac{q}{R} - \frac{q}{\sqrt{R^2 + d^2}} \right) - \frac{1}{4\pi\epsilon_0} \left(-\frac{q}{R} + \frac{q}{\sqrt{R^2 + d^2}} \right)$$

$$= \frac{1}{4\pi\epsilon_0} \frac{q}{R} + \frac{1}{4\pi\epsilon_0} \frac{q}{R} - \frac{1}{4\pi\epsilon_0} \frac{q}{\sqrt{R^2 + d^2}} - \frac{1}{4\pi\epsilon_0} \frac{q}{\sqrt{R^2 + d^2}}$$

$$= \frac{1}{2\pi\epsilon_0} \left(\frac{q}{R} - \frac{q}{\sqrt{R^2 + d^2}} \right)$$

59. Each plate is taking part in the formation of two capacitors except the plates at the ends.

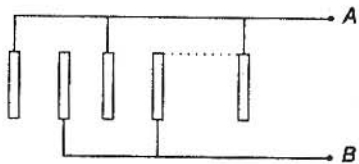

These capacitors are in parallel and n plates form $(n - 1)$ capacitors.

Thus, equivalent capacitance between A and B = $(n - 1)C$.

60. The frequency of fork 2

$$= 200 \pm 4 = 196 \text{ or } 204 \text{ Hz}$$

Since, on attaching the tape on the prong of fork 2, its frequency decreases, but now the number of beats per second is 6 i.e., the frequency difference now increases. It is possible only when before attaching the tape, the frequency of fork 2 is less than the frequency of tuning fork 1. Hence, the frequency of fork 2 is 196 Hz.

61. $\frac{d^2x}{dt^2} = -\alpha x \quad \dots(i)$

We know

$$a = \frac{d^2x}{dt^2} = -\omega^2 x \quad \dots(ii)$$

From Eqs. (i) and (ii), we have

$$\omega^2 = \alpha$$

$$\omega = \sqrt{\alpha}$$

or $\frac{2\pi}{T} = \sqrt{\alpha}$

$\therefore T = \frac{2\pi}{\sqrt{\alpha}}$

62.

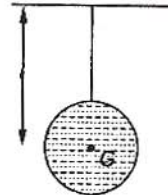

Spherical hollow ball filled with water

$$T = 2\pi\sqrt{\frac{l}{g}}$$

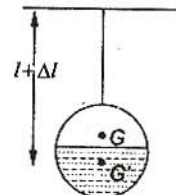

Spherical hollow ball half filled with water

$$T_1 = 2\pi\sqrt{\frac{l+\Delta l}{g}}$$

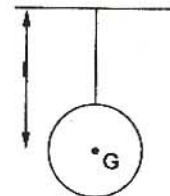

Spherical hollow ball

$$T_2 = 2\pi\sqrt{\frac{l}{g}}$$

and $T_1 > T_2$

Hence, time period first increases and then decreases to the original value.

63. Given : $v_o = \frac{v}{5} \Rightarrow v_o = \frac{320}{5} = 64 \text{ m/s}$

When observer moves towards the stationary source, then

$$n' = \left(\frac{v + v_o}{v} \right) n$$

$$n' = \left(\frac{320 + 64}{320} \right) n$$

$$n' = \left(\frac{384}{320} \right) n$$

$$\frac{n'}{n} = \frac{384}{320}$$

Hence, percentage increase

$$\left(\frac{n' - n}{n} \right) = \left(\frac{384 - 320}{320} \times 100 \right) \%$$

$$= \left(\frac{64}{320} \times 100 \right) \% = 20 \%$$

$$64. I = I_0 \left(\frac{\sin \theta}{\theta} \right)^2$$

$$\text{and } \theta = \frac{\pi}{\lambda} \left(\frac{ay}{D} \right)$$

For principal maximum $y = 0$

$$\therefore \theta = 0$$

Hence, intensity will remain same.

$$65. B_p = \frac{\mu_0 I_2}{2R}$$

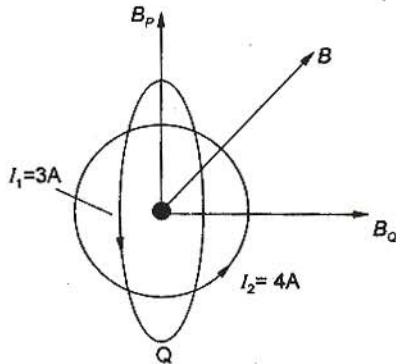

$$= \frac{4\pi \times 10^{-7} \times 4}{2 \times 0.02\pi} = 4 \times 10^{-5} \text{ Wb/m}^2$$

$$B_q = \frac{\mu_0 I_1}{2R}$$

$$= \frac{4\pi \times 10^{-7} \times 3}{2 \times 0.02\pi} = 3 \times 10^{-5} \text{ Wb/m}^2$$

$$\therefore B = \sqrt{B_p^2 + B_q^2}$$

$$= \sqrt{(4 \times 10^{-5})^2 + (3 \times 10^{-5})^2}$$

$$= 5 \times 10^{-5} \text{ Wb/m}^2$$

66. The current at any instant is given by

$$I = I_0 (1 - e^{-Rt/L})$$

$$\frac{I_0}{2} = I_0 (1 - e^{-Rt/L})$$

$$\frac{1}{2} = (1 - e^{-Rt/L})$$

$$e^{-Rt/L} = 1/2$$

$$\frac{Rt}{L} = \ln 2$$

$$\therefore t = \frac{L}{R} \ln 2 = \frac{300 \times 10^{-3}}{2} \times 0.693$$

$$= 150 \times 0.693 \times 10^{-3}$$

$$= 0.10395 \text{ s} = 0.1 \text{ s}$$

67. Given : $L = 10 \text{ H}$, $f = 50 \text{ Hz}$

For maximum power

$$X_C = X_L$$

$$\frac{1}{\omega C} = \omega L$$

$$C = \frac{1}{\omega^2 L}$$

$$\therefore C = \frac{1}{4\pi^2 \times 50 \times 50 \times 10}$$

$$C = 0.1 \times 10^{-5} \text{ F} = 1 \mu\text{F}$$

$$68. I = \frac{E}{R+r}$$

$$I = \frac{E}{R} = \text{constant}$$

where, R = external resistance

r = internal resistance

$$= 0$$

69. Power factor

$$= \cos \phi = \frac{R}{Z}$$

$$= \frac{12}{15} = \frac{4}{5} = 0.8$$

70. 1. In a circuit having C alone, the voltage lags the current by $\frac{\pi}{2}$.

2. In circuit containing R and L , the voltage leads the current by $\frac{\pi}{2}$.

3. In LC circuit, the phase difference between current and voltage can have any value between 0 to $\frac{\pi}{2}$ depending on the values of L and C .

4. In a circuit containing L alone, the voltage leads the current by $\frac{\pi}{2}$.

71. When \vec{E} , \vec{v} and \vec{B} are all along same direction, then magnetic force experienced by electron is zero while electric force is acting opposite to velocity of electron, so velocity of electron will decrease.

72. Magnetic force $F = qvB$... (i)

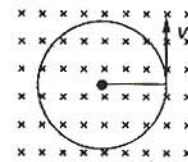

Centripetal force

$$F = \frac{mv^2}{r} \dots (ii)$$

From Eqs. (i) and (ii),

$$\frac{mv^2}{r} = qvB$$

$$r = \frac{mv}{qB}$$

The time taken by the particle to complete one revolution,

$$\begin{aligned} T &= \frac{2\pi r}{v} \\ &= \frac{2\pi mv}{vqB} \\ &= \frac{2\pi m}{qB} \end{aligned}$$

73. The internal resistance of the cell

$$\begin{aligned} r &= \left(\frac{l_1 - l_2}{l_2} \right) R \\ &= \frac{240 - 120}{120} \times 2 = 2\Omega \end{aligned}$$

74. $P = \frac{V^2}{R}$

$$\begin{aligned} R_{\text{hot}} &= \frac{V^2}{P} \\ &= \frac{200 \times 200}{100} \\ &= 400\Omega \\ R_{\text{cold}} &= \frac{400}{10} \\ &= 40\Omega \end{aligned}$$

75. Magnetic needle is placed in non-uniform magnetic field. It experiences force and torque both due to unequal forces acting on poles.

Chemistry

76. $[\text{Cr}(\text{NH}_3)_4\text{Cl}_2]^+$

Let oxidation state of Cr = x
 $\text{NH}_3 = 0$
 $\text{Cl} = -1$

Net charge = +1

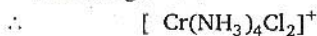

$$x + 4 \times 0 + 2(-1) = +1$$

$$\therefore x = 3$$

77. Antipyretic drugs reduce fever. Analgesic relieves in pain, antibiotics act against bacterial infections while tranquilisers are used against mental disorders.
78. A species is amphoteric if it is soluble in acid (behaves as a base) as well as in base (behaves as an acid).



79. A species is said to be diamagnetic if it has all electrons paired.

Species	Electrons	MO Electronic configuration	Magnetic behaviour
H_2^-	3	$\sigma 1s^2 \sigma^* 1s^1$	Paramagnetic
H_2^+	1	$\sigma 1s^1$	Paramagnetic
H_2	2	$\sigma 1s^2$	Diamagnetic
He_2^+	3	$\sigma 1s^2 \sigma^* 1s^1$	Paramagnetic



van't Hoff factor $i = [1 + (y - 1)\alpha]$
 where y is the number of ions from one mole solute, (in this case = 3), α the degree of dissociation.
 $i = (1 + 2\alpha)$

81. Nylon-66 is a polyamide of **hexamethylene diamine** $(\text{CH}_2)_6(\text{NH}_2)_2$ and adipic acid $(\text{CH}_2)_4(\text{COOH})_2$.
 (Each reactant has six-carbon chain hence trade code (66) is used.)

82. Free radicals have unpaired electrons but are neutrals and are reactive.



83. $\Delta G^\circ = -2.303RT \log K_{eq}$

$$\Delta G^\circ = -nFE_{\text{cell}}^\circ$$

If a cell reaction is spontaneous (proceeding in forward side), it means

$$K_{eq} > 1 \text{ and } E_{\text{cell}}^\circ = +ve$$

Thus $\Delta G^\circ = -ve$

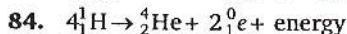

It is the principal reaction of **Hydrogen-bomb**.

85. Unit cell consists of A ions at the corners.

Thus number of ions of the type

$$A = \frac{8}{8} = 1$$

Unit cell consists of B ions at the centre of the six faces.

Thus number of ions of the type

$$B = \frac{6}{2} = 3$$

[Each corners is shared by 8 cubes and each face is shared by 2 faces]

Thus formula is AB_3 .

86. Fluoro group causes negative inductive effect increasing ionisation, thus 0.1 M difluoroacetic acid has highest electrical conductivity.

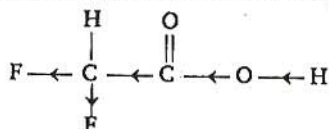

87. Greater the charge, smaller the radius, greater the polarising power and thus greater the covalent nature. This leads to increase in lattice energy.

88. $X \rightarrow Y$ is an endothermic reaction $\Delta H = +ve$

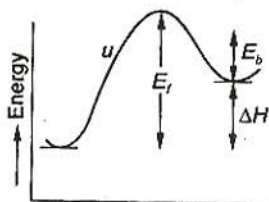

E_b = energy of activation of backward reaction
 E_f = energy of activation of forward reaction
 ΔH = heat of reaction

Thus $E_f = E_b + \Delta H$

Thus $E_f > E_b$

89. $\text{Al}^{3+} + 3e^- \rightarrow \text{Al}$

$$w = zQ$$

where w = amount of metal

$$= 5.12 \text{ kg} = 5.12 \times 10^3 \text{ g}$$

z = electrochemical equivalent

$$= \frac{\text{Equivalent weight}}{96500} = \frac{\text{Atomic mass}}{\text{Electrons} \times 96500}$$

$$= \frac{27}{3 \times 96500}$$

$$5.12 \times 10^3 = \frac{27}{3 \times 96500} \times Q$$

$$Q = \frac{5.12 \times 10^3 \times 3 \times 96500}{27} \text{ C}$$

$$= 5.49 \times 10^7 \text{ C}$$

90. Size of colloidal particles = 1 to 100 nm (say 10 nm)

$$V_C = \frac{4}{3} \pi r^3 = \frac{4}{3} \pi (10)^3$$

Size of true solution particles $\approx 1 \text{ nm}$

$$V_S = \frac{4}{3} \pi (1)^3$$

Thus $\frac{V_C}{V_S} = 10^3$

91. $\Delta H = \Delta U + \Delta n_g RT$

ΔH = enthalpy change (at constant pressure)

ΔU = internal energy change (at constant volume) (given reaction is exothermic)

Δn_g = mole of (gaseous products - gaseous reactants)

= -ve

Thus $\Delta H < \Delta U$.

Note: Numerical value of $\Delta H < \Delta U$ in exothermic reaction and when $\Delta n_g < 0$

92. $\text{MX}_2 \rightleftharpoons \text{M}^{2+} + 2\text{X}^-$

$$K_{sp} = [\text{M}^{2+}][\text{X}^-]^2$$

If solubility be s then

$$K_{sp} = (s)(2s)^2 = 4s^3$$

$$4s^3 = 4 \times 10^{-12}$$

$$\therefore s = 1 \times 10^{-4} \text{ M}$$

$$\therefore \text{M}^{2+} = s = 1 \times 10^{-4} \text{ M}$$

93. Mixture contains 78g benzene = 1 mole benzene and 46 g toluene = 0.5 mole toluene

Total mole of benzene and toluene = 1.5 mol

Mole fraction of benzene in mixture = $\frac{1}{1.5} = \frac{2}{3}$

VP of benzene $p_b^\circ = 75 \text{ torr}$

\therefore partial vapour pressure of benzene = $p_b^\circ X_b$

$$= 75 \times \frac{2}{3} = 50 \text{ torr}$$

94. Distribution of molecules (N) with velocity (u) at two temperatures T_1 and T_2 ($T_2 > T_1$) is shown below:

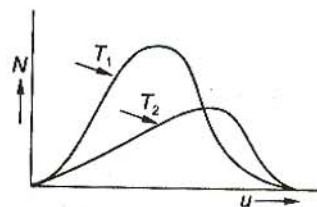

At both temperatures, distribution of molecules with increase in velocity first increases, reaches a maximum value and then decreases.

95. $2\text{NO}_2(\text{g}) \rightleftharpoons 2\text{NO}(\text{g}) + \text{O}_2(\text{g})$

$$K_c = 1.8 \times 10^{-6} \text{ at } 184^\circ \text{C} (= 457 \text{ K})$$

$$R = 0.00831 \text{ kJ mol}^{-1} \text{ K}^{-1}$$

$$K_p = K_c (RT)^{\Delta n_g}$$

where,

$$\Delta n_g = (\text{gaseous products} - \text{gaseous reactants})$$

$$= 3 - 2 = 1$$

$$\therefore K_p = 1.8 \times 10^{-6} \times 0.00831 \times 457$$

$$= 6.836 \times 10^{-6} > 1.8 \times 10^{-6}$$

Thus $K_p > K_c$

96. Reaction is exothermic. By Le-Chatelier principle, a reaction is spontaneous in forward side (in the direction of formation of more ClF_3) if F_2 is added, temperature is lowered and ClF_3 is removed.

97. $\text{pH} = 5.4$

$$\therefore [\text{H}^+] = 10^{-5.4} = 10^{-6} \cdot 10^{0.6}$$

Antilog of 0.6 is ≈ 4

$$\therefore [\text{H}^+] \approx 4 \times 10^{-6} \text{ M}$$

98. There are two different reactants (say A and B).

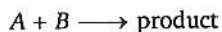

Thus it is a bimolecular reaction.

$$\text{If } \frac{dx}{dt} = k[A][B]$$

it is second-order reaction

$$\text{If } \left(\frac{dx}{dt}\right) = k[A]$$

$$\text{or } = k[B]$$

it is first order reaction.

Molecularity is independent of rate, but is the sum of the reacting substances thus it cannot be unimolecular reaction.

99. Total molarity = $\frac{M_1V_1 + M_2V_2}{V_1 + V_2}$
- $$= \frac{1.5 \times 480 + 1.2 \times 520}{480 + 520}$$
- $$= 1.344 \text{ M}$$

100. During electrolysis, noble metals (inert metals) like **Ag**, **Au** and **Pt** are not affected and separate as anode mud from the impure anode.

101. $\Delta_{\text{AcOH}}^\circ = \Delta_{\text{AcONa}}^\circ + \Delta_{\text{HCl}}^\circ - \Delta_{\text{NaCl}}^\circ$
- $$= 91.0 + 426.2 - 126.5$$
- $$= 390.7$$

102. Remains unchanged.

103. (A) 1s (B) 2s
(C) 2p (D) 3d
(E) 3d

In the absence of any field, 3d in (D) and (E) will be of equal energy.

104. As we go down in the group, ionic character increases hence, melting point of halides should increase but NaCl has the highest melting point (800°C) due to its high lattice energy.

105. Variation of K_{eq} with temperature T is given by van't Hoff equation.

$$\log K_{eq} = -\frac{\Delta H^\circ}{2.303 RT} + \frac{\Delta S^\circ}{R}$$

Slope of the given line is +ve indicating that term A is positive thus ΔH° is -ve.

Thus reaction is exothermic.

106. Following reaction takes place during bessemerisation :

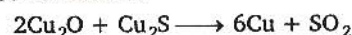

- 107.

Molecule	Structure	Hybridisation of central atom	Lone pair
SF_4	$\begin{array}{c} \text{F} \\ \\ \text{F}-\text{S}-\text{F} \\ \\ \text{F} \end{array}$	sp^3d	one
CF_4	$\begin{array}{c} \text{F} \\ \\ \text{F}-\text{C}-\text{F} \\ \\ \text{F} \end{array}$	sp^3	zero
XeF_4	$\begin{array}{c} \text{F} \\ \\ \text{F}-\text{Xe}-\text{F} \\ \\ \text{F} \end{array}$	sp^3d^2	two

108. Mixing the soles together can cause coagulation since the charges are neutralised.

109. Hypophosphorus acid (H_3PO_2) is a monobasic acid and has only one ionisable H, two H-atoms are directly attached to phosphorus. Thus the correct statement is (c).

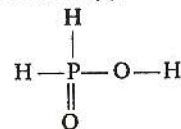

110. Conjugate base is formed by loss of H^+ .

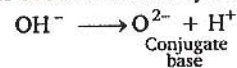

O^{2-} is the conjugate base of OH^- .

111. Aqueous solution of AlCl_3 is acidic due to hydrolysis.



On strongly heating $\text{Al}(\text{OH})_3$ is converted into Al_2O_3

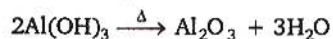

112. In a group, $\Delta G_f^\circ(\text{HX})$ changes from -ve to +ve downwards.

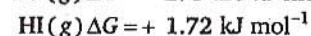
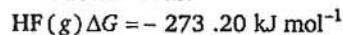

Thus HF is thermally stable and HI not.

Thus $\text{HF} > \text{HCl} > \text{HBr} > \text{HI}$

113. $\text{Hg}_2\text{Cl}_2 + 2\text{NH}_3 \rightarrow \text{HgNH}_2\text{Cl} + \text{Hg} + \text{NH}_4\text{Cl}$
white black

114. CaC_2 (Calcium carbide) is ionic.

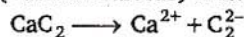

C_2^{2-} has one σ and two π bonds.

115. $\text{Cr}_2\text{O}_7^{2-} + 14\text{H}^+ + 6\text{I}^- \rightarrow 2\text{Cr}^{3+} + 7\text{H}_2\text{O} + 3\text{I}_2$

$\text{Cr}_2\text{O}_7^{2-}$ is reduced to Cr^{3+} .

Thus final state of Cr is +3. Hence, (a)

- 116.

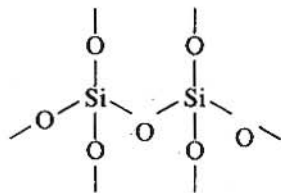

117. Lanthanide contraction, cancels almost exactly the normal size increase on descending a group of transition elements, thus Nb and Ta and, Zr and Hf have same covalent and ionic radii.

118. $\text{K}_3[\text{Fe}(\text{CN})_6]$

Cation Anion

Oxidation state of Fe in anion = +3

Thus it is potassium hexacyanoferrate (III).

119. (a) Metallic radii increase in a group from top to bottom.

Thus $\text{Li} < \text{Na} < \text{K} < \text{Rb}$ — True

- (b) Electron gain of enthalpy of $\text{Cl} > \text{F}$ and decreases along a group

Thus $\text{I} < \text{Br} < \text{F} < \text{Cl}$ is true.

- (c) Ionisation enthalpy increases along a period left to right but due to presence of half-filled orbitals in N, ionisation enthalpy of $\text{N} > \text{O}$.

Thus $\text{B} < \text{C} < \text{N} < \text{O}$ is incorrect.

- 120.

Species	Electron in central element	Electrons in other element	Charge gained	Total
BO_3^{3-}	5	$3 \times 8 = 24$	+3	32
CO_3^{2-}	6	$3 \times 8 = 24$	+2	32
NO_3^-	7	$3 \times 8 = 24$	+1	32
SO_3^{2-}	16	$3 \times 8 = 24$	+2	42
CN^-	6	7	1	14
N_2	7	7	0	14
C_2^{2-}	6	6	+2	14
PO_4^{3-}	15	$4 \times 8 = 32$	+3	50
SO_4^{2-}	16	$4 \times 8 = 32$	+2	50
ClO_4^-	17	$4 \times 8 = 32$	+1	50

Thus (a) BO_3^{3-} , CO_3^{2-} , NO_3^- are isoelectronic.

(b) SO_3^{2-} , CO_3^{2-} , NO_3^- are not isoelectronic.

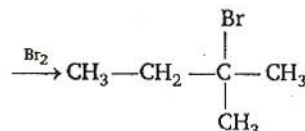
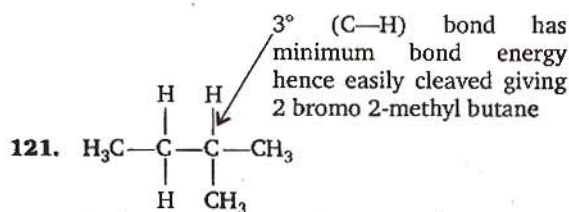

- 122.

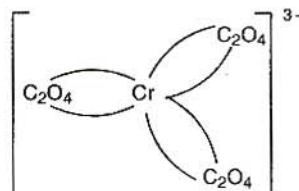

Mirror image is not superimposable hence, optical isomerism is possible.

- 123.

	Hybridisation	Unpaired electrons	Magnetic moment
(a) $[\text{Co}(\text{CN})_6]^{3-}$	d^2sp^3	0	0
(b) $[\text{Fe}(\text{CN})_6]^{3-}$	d^2sp^3	1	$\sqrt{3}$ BM
(c) $[\text{Mn}(\text{CN})_6]^{3-}$	d^2sp^3	2	$\sqrt{8}$ BM
(d) $[\text{Cr}(\text{CN})_6]^{3-}$	d^2sp^3	3	$\sqrt{15}$ BM

Thus least paramagnetism is in (a).

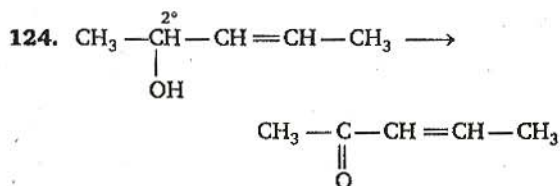

Only **suitable reagent** is chromic anhydride in glacial acetic acid. Other will also effect (C=C) bond.

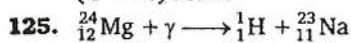

Thus nuclide of ${}^{23}_{11}\text{Na}$ is formed.

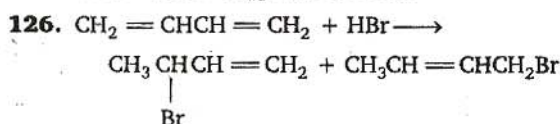

1,2-addition product 1,4-addition product
Addition is through the formation of allylic carbocation

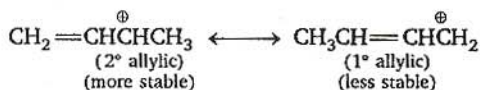

Under mild conditions (temperature $\approx -80^\circ\text{C}$) **kinetic product** is the **1, 2-addition product** and under vigorous conditions (temp. $\approx 40^\circ\text{C}$) **thermodynamic product** is the **1, 4-addition product**.

Thus 1-bromo-2-butene is the major product under given condition.

127. If acid is weak, its conjugate base (nucleophile) is strong and *vice versa*.

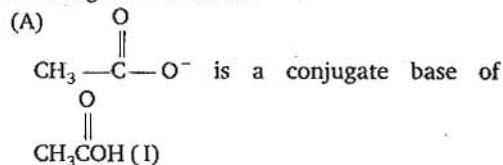

(B) CH_3O^- is a conjugate base of CH_3OH (II)

(C) CN^- is a conjugate base of HCN (III)

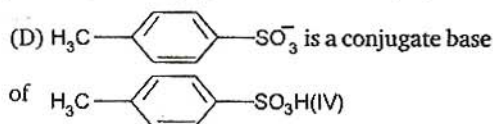

Acidic nature of $\text{IV} > \text{I} > \text{III} > \text{II}$
and nucleophilicity of $\text{B} > \text{C} > \text{A} > \text{D}$

128. In $\text{S}_\text{N}2$ reaction, nucleophile and alkyl halide react in one step.

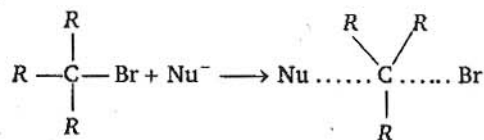

Thus tertiary carbon is under steric hindrance thus reaction does not take place until (C-Br) bond breaks

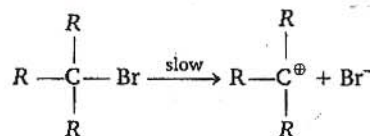

which is then $\text{S}_\text{N}1$ reaction.

129. Synthesis of RNA/DNA from phosphoric acid, ribose and cytosine is given below
Thus ester linkages are at C_5' and C_1' of sugar molecule.

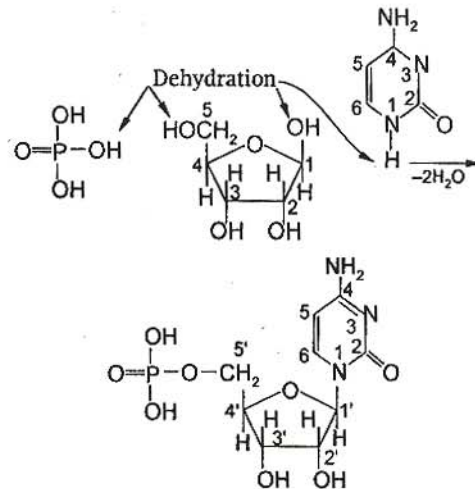

130. Out of the given acids, strongest is HCOOH . (highest K_a value)
Since $\text{p}K_a = -\log K_a$
Thus lowest $\text{p}K_a$ is of HCOOH .

131. (A) 2-methyl pentane $\xrightarrow{\text{Cl}_2}$ five types of monochlorinated compounds
(B) 2, 2-dimethylbutane $\xrightarrow{\text{Cl}_2}$ three types....
(C) 2, 3-dimethylbutane $\xrightarrow{\text{Cl}_2}$ two types
(D) *n*-hexane $\xrightarrow{\text{Cl}_2}$ three types

132. It is Corey House synthesis of alkanes.

133. Wurtz reaction is used to prepare alkanes from alkyl halides :

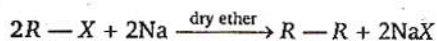

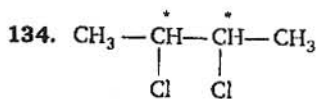

There are two chiral C-atoms (*)
Thus optical isomerism is possible.

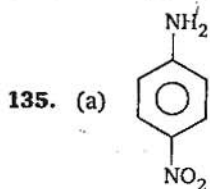

NO_2 group (electron withdrawing) decreases basic nature of aniline.

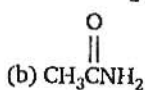

$\text{CH}_3\text{C}(=\text{O})$ group is also electron withdrawing.

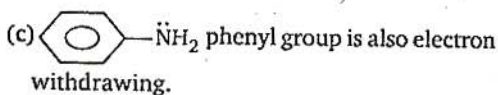

(d) Benzyl is electron-repelling group increases basic nature.

Thus most basic compound is benzylamine.

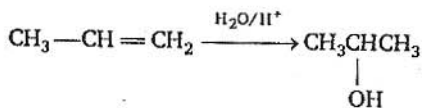
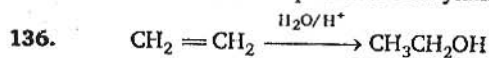

(2° alcohol) through 2° carbocation $\text{CH}_3\overset{\oplus}{\text{C}}\text{HCH}_3$

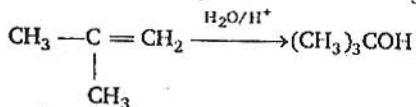

(3° alcohol) through 3° carbocation $(\text{CH}_3)_3\overset{\oplus}{\text{C}}$

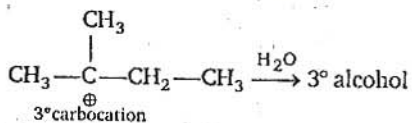
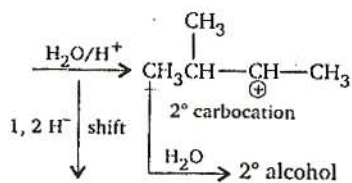
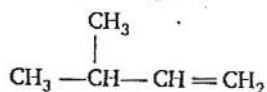

Thus best alternate is (c)

137. Teflon is $-\text{CF}_2 - \text{CF}_2 -$

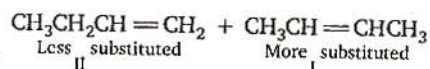
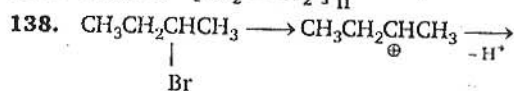

Stability of I > II hence I is predominant.

139. Boiling point and freezing point depend on K_b (molal elevation constant) and K_f (molal depression constant) of the solvent. Thus equimolar solution (of the non-electrolyte) will have same boiling point and also same freezing point.

$$\Delta T_f = K_f \times \text{molality}$$

$$\Delta T_b = K_b \times \text{molality}$$

Note: In question (139) set C, nature of solute has not been mentioned. Hence, we have assumed that solute is non-electrolyte.

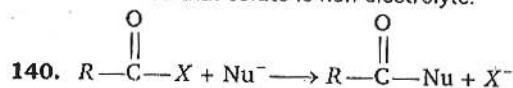

Best leaving group (poorest nucleophile) is Cl^- , thus fastest reaction is with Cl.

141. B_2H_6 has structure

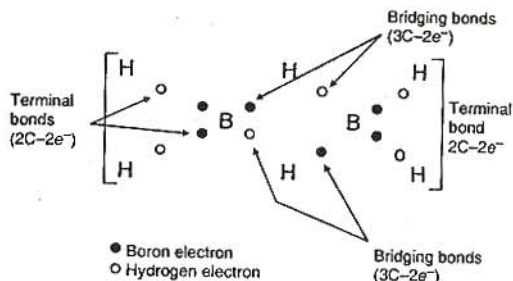

142. Hydrogen atom is in $1s^1$ and these 3s, 3p and 3d orbitals will have same energy w.r.t. 1s orbital.

143. Lanthanide contraction is due to poor shielding of one of 4f electron by another in the sub-shell.

144. (a) d^5 in strong field

$$n = \text{unpaired electron} = 1$$

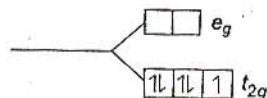

$$\text{Magnetic moment} = \sqrt{n(n+2)} \text{ BM}$$

$$= \sqrt{3} \text{ BM} = 1.73 \text{ BM}$$

(b) d^3 in strong/weak field

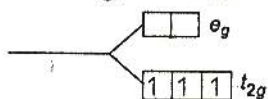

$$n = 3$$

$$\text{Magnetic moment} = \sqrt{15} = 3.87 \text{ BM}$$

(c) d^4 in weak field

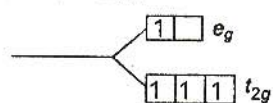

$$n = 4$$

$$\text{Magnetic moment} = \sqrt{24} = 4.90 \text{ BM}$$

(d) d^4 in strong field

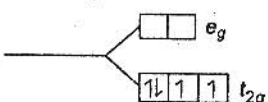

$$n = 2$$

$$\text{Magnetic moment} = \sqrt{8} = 2.83 \text{ BM}$$

145.

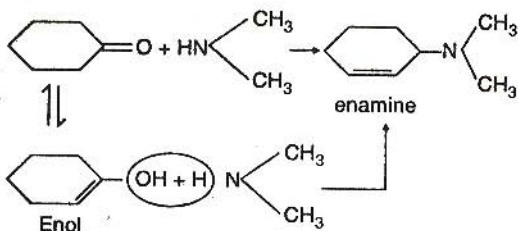

146.

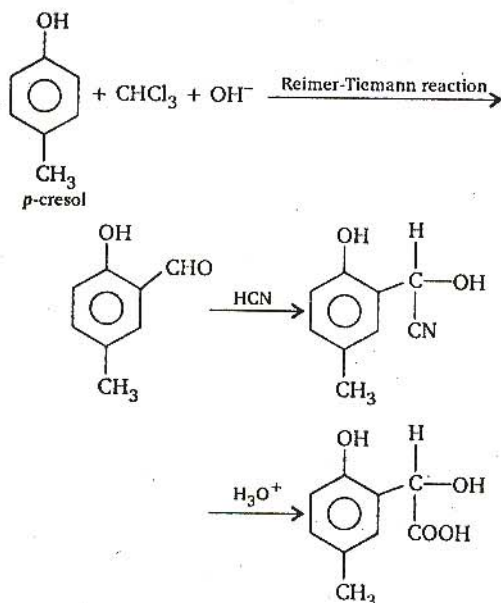

(—OH is more activating than —CH₃ in *o*, *p*-directing, thus —CHO goes to *ortho* w.r.t —OH)

147. Formation of XY is shown as

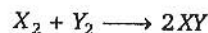

$$\Delta H = (\text{BE})_{X-X} + (\text{BE})_{Y-Y} - 2(\text{BE})_{X-Y}$$

If (BE) of $X-Y = a$

then (BE) of $(X-X) = a$

and (BE) of $(Y-Y) = \frac{a}{2}$

$$\therefore \Delta H_f (X-Y) = -200 \text{ kJ}$$

$$\therefore -400 \text{ (for 2 mol XY)} = a + \frac{a}{2} - 2a$$

$$-400 = -\frac{a}{2}$$

$$a = +800 \text{ kJ}$$

The bond dissociation energy of $X_2 = 800 \text{ kJ mol}^{-1}$

148.

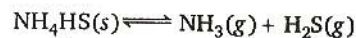

initially 1 0.5 0

at equilibrium $(1-x)$ $(0.5+x)$ x

Total pressure at equilibrium

$$= P_{\text{NH}_3} + P_{\text{H}_2\text{S}}$$

$$= 0.5 + x + x = 0.84$$

$$\therefore x = 0.17 \text{ atm}$$

$$\therefore P_{\text{NH}_3} = 0.50 + 0.17 = 0.67 \text{ atm}$$

$$P_{\text{H}_2\text{S}} = 0.17 \text{ atm}$$

$$\therefore K_p = P_{\text{NH}_3} \cdot P_{\text{H}_2\text{S}} = 0.67 \times 0.17 = 0.114 \text{ atm}$$

149.

Element	Percentage	Percentage at. wt.	Simple Ratio
C	20.0	$\frac{20.0}{12} = 1.66$	$\frac{1.66}{1.66} = 1$
H	6.67	$\frac{6.67}{1} = 6.67$	$\frac{6.67}{1.66} = 4$
N	46.67	$\frac{46.67}{14} = 3.33$	$\frac{3.33}{1.66} = 2$
O	26.66	$\frac{26.66}{16} = 1.66$	$\frac{1.66}{1.66} = 1$

Empirical formula = $\text{CH}_4\text{N}_2\text{O}$

Empirical formula weight

$$= 12 + (4 \times 1) + (2 \times 14) + 16$$

$$= 60$$

$$\therefore n = \frac{\text{Mol. formula weight}}{\text{Emp. formula weight}} = \frac{60}{60} = 1$$

\therefore Molecular formula = $\text{CH}_4\text{N}_2\text{O}$

Given compound gives biuret test. Thus given compound is urea $(\text{NH}_2)_2\text{CO}$.

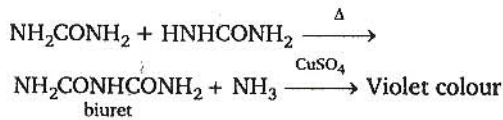

150.

	A	→	Product
initially	a		0
after time t	(a - x)		x
after t _{1/4}	(a - $\frac{a}{4}$)		$\frac{a}{4}$

For first-order kinetics,

$$k = \frac{2.303}{t} \log \left(\frac{a}{a-x} \right)$$

$$\therefore k = \frac{2.303}{t_{1/4}} \log \frac{a}{\frac{3a}{4}}$$

$$t_{1/4} = \frac{2.303 \log \frac{4}{3}}{k} = \frac{0.29}{k}$$

Mathematics

1. **Key Idea :** If C is mid point of AB and P be the

origin, then $\vec{PC} = \frac{\vec{PA} + \vec{PB}}{2}$.

Let P be the origin outside of AB and C is mid point of AB, then

$$\vec{PC} = \frac{\vec{PA} + \vec{PB}}{2}$$

$$\Rightarrow 2\vec{PC} = \vec{PA} + \vec{PB}$$

2. The co-ordinates of P are (1, 0). A general point Q on $y^2 = 8x$ is $(2t^2, 4t)$. Mid point of PQ is (h, k) , so

$$2h = 2t^2 + 1 \quad \dots(i)$$

$$\text{and } 2k = 4t \Rightarrow t = k/2 \quad \dots(ii)$$

On putting the value of t from Eq. (ii) in Eq. (i), we get

$$2h = \frac{2k^2}{4} + 1$$

$$\Rightarrow 4h = k^2 + 2$$

So the locus of (h, k) is $y^2 - 4x + 2 = 0$.

3. **Key Idea :** The relation among Mean, Mode and Median of any frequency distribution is

$$\text{Mode} = 3 \text{ Median} - 2 \text{ Mean}.$$

Given that Mean = 21 and Median = 22

$$\therefore \text{Mode} = 3 \text{ Median} - 2 \text{ Mean}$$

$$\begin{aligned} \therefore \text{Mode} &= 3(22) - 2(21) \\ &= 66 - 42 \\ &= 24 \end{aligned}$$

4. Since, $(3, 3), (6, 6), (9, 9), (12, 12) \in R \Rightarrow R$ is reflexive relation.

Now $(6, 12) \in R$ but $(12, 6) \notin R$, so it is not a symmetric relation.

Also $(3, 6), (6, 12) \in R \Rightarrow (3, 12) \in R$

$\Rightarrow R$ is transitive relation.

Note : Any relation is said to be an equivalence relation, if it is reflexive, symmetric and transitive relation simultaneously.

5. **Key Idea :** If A is any square matrix, then

$$AA^{-1} = I \text{ and } A^{-1}A = A^{-1}.$$

Since, $A^2 - A + I = 0$

$$\Rightarrow A^{-1}A^2 - A^{-1}A + A^{-1}I = 0$$

(Pre multiply given relation by A^{-1})

$$\Rightarrow (A^{-1}A)A - (A^{-1}A) + A^{-1}I = 0$$

$$\Rightarrow A - I + A^{-1}I = 0$$

$$\Rightarrow A^{-1} = I - A$$

6. Since $(x-1)^3 + 8 = 0$

$$\Rightarrow (x-1)^3 = -8 = (-2)^3$$

$$\Rightarrow \left(\frac{x-1}{-2} \right)^3 = 1$$

$$\Rightarrow \left(\frac{x-1}{-2} \right) = (1)^{1/3}$$

\therefore roots of $\left(\frac{x-1}{-2} \right)$ are 1, ω and ω^2 .

$$\Rightarrow \text{roots of } (x-1) \text{ are } -2, -2\omega \text{ and } -2\omega^2$$

$$\Rightarrow \text{roots of } x \text{ are } -1, 1-2\omega \text{ and } 1-2\omega^2.$$

Note : If 1, ω and ω^2 are cube roots of unity, then

$$1 + \omega + \omega^2 = 0 \text{ and } \omega^3 = 1$$

7. Let $A = \lim_{n \rightarrow \infty} \left(\frac{1}{n^2} \sec^2 \frac{1}{n^2} + \frac{2}{n^2} \sec^2 \frac{2}{n^2} + \dots + \frac{1}{n} \sec^2 1 \right)$

$$= \lim_{n \rightarrow \infty} \frac{1}{n} \left(\frac{1}{n} \sec^2 \left(\frac{1}{n} \right)^2 + \frac{2}{n} \sec^2 \left(\frac{2}{n} \right)^2 + \dots + \frac{n}{n} \sec^2 \left(\frac{n}{n} \right)^2 \right)$$

$$= \lim_{n \rightarrow \infty} \frac{1}{n} \sum_{r=1}^n \left(\frac{r}{n} \right) \sec^2 \left(\frac{r}{n} \right)^2$$

$$A = \int_0^1 x \sec^2(x^2) dx$$

Let $x^2 = t$

$$\Rightarrow 2x dx = dt \Rightarrow x dx = \frac{dt}{2}$$

$$\therefore A = \frac{1}{2} \int_0^1 \sec^2 t dt$$

$$= \frac{1}{2} [\tan t]_0^1 = \frac{1}{2} \tan 1$$

8. Key Idea : The parametric co-ordinates of a point that lies on an ellipse $\frac{x^2}{a^2} + \frac{y^2}{b^2} = 1$ are $(a \cos \theta, b \sin \theta)$.

Let the co-ordinates of the vertices of rectangle ABCD are A $(a \cos \theta, b \sin \theta)$, B $(-a \cos \theta, b \sin \theta)$, C $(-a \cos \theta, -b \sin \theta)$ and D $(a \cos \theta, -b \sin \theta)$, then length of rectangle, $AB = 2a \cos \theta$ and breadth of rectangle, $AD = 2b \sin \theta$

$$\therefore \text{Area of rectangle} = AB \times AD = 2a \cos \theta \times 2b \sin \theta$$

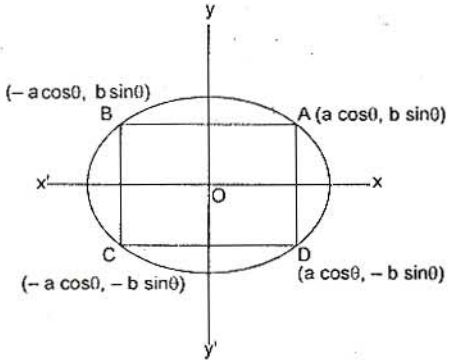
$$\Rightarrow \text{Area of rectangle, } A = 2ab \sin 2\theta \quad \dots(i)$$

$$\therefore \frac{dA}{d\theta} = 2 \times 2ab \cos 2\theta$$

On putting $\frac{dA}{d\theta} = 0$ for maxima or minima.

$$\therefore \frac{dA}{d\theta} = 0$$

$$\Rightarrow \cos 2\theta = 0$$

$$\Rightarrow 2\theta = \frac{\pi}{2} \Rightarrow \theta = \frac{\pi}{4}$$

Now $\frac{d^2A}{d\theta^2} = -8ab \sin^2 \theta$

Now $\left(\frac{d^2A}{d\theta^2} \right)_{\theta = \frac{\pi}{4}} < 0$

\therefore Area is maximum at $\theta = \frac{\pi}{4}$.

$$\Rightarrow \text{Maximum Area of rectangle} = 2ab \text{ sq unit. (From (i))}$$

Alternate Solution

From Eq. (i) Area of rectangle, $A = 2ab \sin 2\theta$

$\therefore A \propto \sin 2\theta$ and $-1 \leq \sin 2\theta \leq 1$

$\therefore A$ is maximum when $\sin 2\theta = 1$

$$\Rightarrow \text{Maximum area of rectangle} = 2ab \text{ sq unit.}$$

9. Key Idea : The differential equation of a family of curves of n parameters is a differential equation of n maximum order.

Equation of family of curves is

$$y^2 = 2c(x + \sqrt{c}) \quad \dots(i)$$

On differentiating Eq. (i) with respect to x , then

$$2yy_1 = 2c$$

$$\Rightarrow c = yy_1$$

On putting the value of c in Eq. (i), we get

$$y^2 = 2yy_1(x + \sqrt{yy_1})$$

$$\Rightarrow (y^2 - 2yy_1x)^2 = 4(yy_1)^3$$

\therefore The degree and order of above equation are 3 and 1 respectively.

10. Key Idea : If three forces acting on a particle keep it in equilibrium, each is proportional to the sine of the angle between the other two.

$$\therefore \frac{P}{\sin \alpha} = \frac{Q}{\sin \beta} = \frac{R}{\sin \gamma}$$

This theorem is known as Lami's theorem.

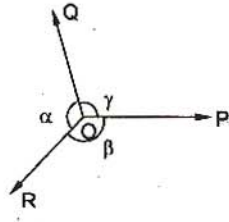

In a $\triangle ABC$, I is the incentre.

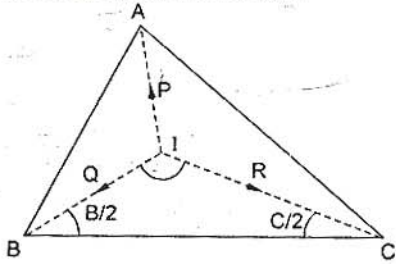

$$\begin{aligned} \therefore \angle BIC &= \pi - \left(\frac{B}{2} + \frac{C}{2} \right) \\ &= \pi - \left(\frac{\pi - A}{2} \right) \\ &= \frac{\pi}{2} + \frac{A}{2} \end{aligned}$$

Similarly, $\angle AIC = \frac{\pi}{2} + \frac{B}{2}$ and $\angle AIB = \frac{\pi}{2} + \frac{C}{2}$

By Lami's theorem

$$\begin{aligned} \frac{\vec{P}}{\sin BIC} &= \frac{\vec{Q}}{\sin AIC} = \frac{\vec{R}}{\sin AIB} \\ \therefore \vec{P} : \vec{Q} : \vec{R} & \\ \equiv \sin \left(\frac{\pi}{2} + \frac{A}{2} \right) : \sin \left(\frac{\pi}{2} + \frac{B}{2} \right) : \sin \left(\frac{\pi}{2} + \frac{C}{2} \right) & \\ \equiv \cos \frac{A}{2} : \cos \frac{B}{2} : \cos \frac{C}{2} & \end{aligned}$$

11. **Key Idea : (1)** The coefficient of $(r+1)$ th term of $(1+y)^m$ is ${}^m C_r$.

(2) If a, b, c are in AP, then $b = \frac{a+c}{2}$.

Since, ${}^m C_{r-1} + {}^m C_{r+1} = 2 {}^m C_r$

$$\begin{aligned} \Rightarrow \frac{m!}{(r-1)!(m-r+1)!} + \frac{m!}{(r+1)!(m-r-1)!} & \\ = 2 \frac{m!}{r!(m-r)!} & \end{aligned}$$

$$\begin{aligned} \Rightarrow \frac{1}{(m-r+1)(m-r)} + \frac{1}{(r+1)r} &= \frac{2}{r(m-r)} \\ \Rightarrow \frac{r(r+1) + (m-r+1)(m-r)}{r(r+1)(m-r+1)(m-r)} &= \frac{2}{r(m-r)} \\ \Rightarrow r^2 + r + m^2 + r^2 - 2mr + m - r & \\ = 2(mr - r^2 + r + m - r + 1) & \end{aligned}$$

$$\Rightarrow 4r^2 - 4mr - m - 2 + m^2 = 0$$

$$\Rightarrow m^2 - m(4r+1) + 4r^2 - 2 = 0$$

12. **Key Idea :** If α and β are the roots of the equation $ax^2 + bx + c = 0$, then $\alpha + \beta = -\frac{b}{a}$ and

$$\alpha\beta = \frac{c}{a}$$

Since, $\tan\left(\frac{P}{2}\right)$ and $\tan\left(\frac{Q}{2}\right)$ are roots of equation $ax^2 + bx + c = 0$.

$$\therefore \tan \frac{P}{2} + \tan \frac{Q}{2} = -\frac{b}{a}$$

$$\text{and } \tan \frac{P}{2} \tan \frac{Q}{2} = \frac{c}{a}$$

$$\text{Also, } \frac{P}{2} + \frac{Q}{2} + \frac{R}{2} = \frac{\pi}{2}$$

(As P, Q, R are angles of a triangle)

$$\Rightarrow \frac{P+Q}{2} = \frac{\pi}{2} - \frac{R}{2} \Rightarrow \frac{P+Q}{2} = \frac{\pi}{4}$$

$$\text{Now, } \tan\left(\frac{P}{2} + \frac{Q}{2}\right) = 1$$

$$\Rightarrow \frac{\tan \frac{P}{2} + \tan \frac{Q}{2}}{1 - \tan \frac{P}{2} \tan \frac{Q}{2}} = 1$$

$$\Rightarrow \frac{-\frac{b}{a}}{1 - \frac{c}{a}} = 1 \Rightarrow -\frac{b}{a} = 1 - \frac{c}{a}$$

$$\Rightarrow -b = a - c \Rightarrow c = a + b$$

Alternate Solution

$$\therefore \angle R = \frac{\pi}{2}$$

$$\Rightarrow \angle P + \angle Q = \frac{\pi}{2}$$

$$\Rightarrow \frac{\angle P}{2} = \frac{\pi}{4} - \frac{\angle Q}{2}$$

$$\therefore \tan\left(\frac{P}{2}\right) = \tan\left(\frac{\pi}{4} - \frac{Q}{2}\right)$$

$$\begin{aligned} &= \frac{\tan \frac{\pi}{4} - \tan \frac{Q}{2}}{1 + \tan \frac{\pi}{4} \tan \frac{Q}{2}} \end{aligned}$$

$$\Rightarrow \tan \frac{P}{2} + \tan \frac{P}{2} \tan \frac{Q}{2} = 1 - \tan \frac{Q}{2}$$

$$\Rightarrow \tan \frac{P}{2} + \tan \frac{Q}{2} = 1 - \tan \frac{P}{2} \tan \frac{Q}{2}$$

$$\Rightarrow -\frac{b}{a} = 1 - \frac{c}{a} \Rightarrow -b = a - c$$

$$\Rightarrow c = a + b$$

13. In SACHIN order of alphabets is A,C,H,I,N,S.

Number of words start with A = 5!, so with C, H, I, N, Now words start with S, and after that ACHIN are in ascending orders of position so $5 \cdot 5! = 600$ words are in dictionary before words with S start and position of this word is 601.

14. **Key Idea :** ${}^nC_r + {}^nC_{r+1} = {}^{n+1}C_{r+1}$.

$$\begin{aligned} \text{Now, } & {}^{50}C_4 + {}^{55}C_3 + {}^{54}C_3 + {}^{53}C_3 + {}^{52}C_3 \\ & \quad + {}^{51}C_3 + {}^{50}C_3 \\ &= {}^{50}C_3 + {}^{50}C_4 + {}^{51}C_3 + {}^{52}C_3 + {}^{53}C_3 \\ & \quad + {}^{54}C_3 + {}^{55}C_3 \\ &= {}^{51}C_4 + {}^{51}C_3 + {}^{52}C_3 + {}^{53}C_3 + {}^{54}C_3 + {}^{55}C_3 \\ & \quad (\because {}^nC_r + {}^nC_{r-1} = {}^{n+1}C_r) \\ &= {}^{52}C_4 + {}^{52}C_3 + {}^{53}C_3 + {}^{54}C_3 + {}^{55}C_3 \\ &= {}^{53}C_4 + {}^{53}C_3 + {}^{54}C_3 + {}^{55}C_3 \\ &= {}^{54}C_4 + {}^{54}C_3 + {}^{55}C_3 \\ &= {}^{55}C_4 + {}^{55}C_3 = {}^{56}C_4 \end{aligned}$$

15. $A = \begin{bmatrix} 1 & 0 \\ 1 & 1 \end{bmatrix}$

$$A^2 = \begin{bmatrix} 1 & 0 \\ 1 & 1 \end{bmatrix} \begin{bmatrix} 1 & 0 \\ 1 & 1 \end{bmatrix}$$

$$A^2 = \begin{bmatrix} 1 & 0 \\ 2 & 1 \end{bmatrix}$$

$$A^3 = \begin{bmatrix} 1 & 0 \\ 2 & 1 \end{bmatrix} \begin{bmatrix} 1 & 0 \\ 1 & 1 \end{bmatrix}$$

$$= \begin{bmatrix} 1 & 0 \\ 3 & 1 \end{bmatrix}$$

$A^n = \begin{bmatrix} 1 & 0 \\ n & 1 \end{bmatrix}$ can be verified by induction.

Now, go option by option

(b) $\begin{bmatrix} 1 & 0 \\ n & 1 \end{bmatrix} \neq \begin{bmatrix} n & 0 \\ n & n \end{bmatrix} + \begin{bmatrix} n-1 & 0 \\ 0 & n-1 \end{bmatrix}$

(d) $nA - (n-1)I = \begin{bmatrix} n & 0 \\ n & n \end{bmatrix} - \begin{bmatrix} n-1 & 0 \\ 0 & n-1 \end{bmatrix}$
 $= \begin{bmatrix} 1 & 0 \\ n & 1 \end{bmatrix}$

16. **Key Idea :** The $(r+1)$ th term in the expansion of $(x+a)^n$ is ${}^nC_r x^{n-r} a^r$.

Let x^7 is contained in $(r+1)$ th term in the expansion of $\left(ax^2 + \frac{1}{bx}\right)^{11}$.

$$\begin{aligned} \therefore T_{r+1} &= {}^{11}C_r (ax^2)^{11-r} \left(\frac{1}{bx}\right)^r \\ &= {}^{11}C_r \frac{a^{11-r}}{b^r} \cdot x^{22-3r} \end{aligned}$$

$$\Rightarrow 22 - 3r = 7$$

$$\Rightarrow 3r = 15$$

$$\Rightarrow r = 5$$

$$\therefore T_6 = {}^{11}C_5 \frac{a^6}{b^5} \cdot x^7$$

\therefore Coefficient of x^7 in the expansion of $\left(ax^2 + \frac{1}{bx}\right)^{11} = {}^{11}C_5 \frac{a^6}{b^5}$

Similarly, coefficient of x^{-7} in the expansion of

$$\left(ax - \frac{1}{bx^2}\right)^{11} = {}^{11}C_6 \frac{a^5}{b^6}$$

According to question,

$${}^{11}C_5 \frac{a^6}{b^5} = {}^{11}C_6 \frac{a^5}{b^6}$$

$$\Rightarrow \frac{a^6}{b^5} = \frac{a^5}{b^6}$$

$$\Rightarrow ab = 1$$

17. Since $x \in (-1, 1)$

$$\Rightarrow \tan^{-1} x \in \left(-\frac{\pi}{4}, \frac{\pi}{4}\right)$$

$$\Rightarrow 2 \tan^{-1} x \in \left(-\frac{\pi}{2}, \frac{\pi}{2}\right)$$

$$\text{and } f(x) = \tan^{-1} \frac{2x}{1-x^2} = 2 \tan^{-1} x, (x^2 < 1).$$

$$\text{So, } f(x) \in \left(-\frac{\pi}{2}, \frac{\pi}{2}\right)$$

\therefore Function is one-one onto.

18. Let $z_1 = x_1 + iy_1$ and $z_2 = x_2 + iy_2$

Now given that

$$|z_1 + z_2| = |z_1| + |z_2|$$

$$\begin{aligned} \Rightarrow \sqrt{(x_1 + x_2)^2 + (y_1 + y_2)^2} \\ = \sqrt{x_1^2 + y_1^2} + \sqrt{x_2^2 + y_2^2} \end{aligned}$$

$$\Rightarrow x_1^2 + x_2^2 + 2x_1x_2 + y_1^2 + y_2^2 + 2y_1y_2$$

$$= x_1^2 + y_1^2 + x_2^2 + y_2^2 + 2\sqrt{(x_1^2 + y_1^2)(x_2^2 + y_2^2)}$$

$$\Rightarrow (x_1x_2 + y_1y_2) = \sqrt{(x_1^2 + y_1^2)(x_2^2 + y_2^2)}$$

$$\begin{aligned} \Rightarrow x_1^2x_2^2 + y_1^2y_2^2 + 2x_1x_2y_1y_2 \\ = x_1^2x_2^2 + y_1^2y_2^2 + x_1^2y_2^2 + y_1^2x_2^2 \end{aligned}$$

$$\Rightarrow x_1y_2 - y_1x_2 = 0$$

$$\Rightarrow \frac{y_2}{x_2} = \frac{y_1}{x_1}$$

$$\Rightarrow \tan^{-1} \left(\frac{y_2}{x_2}\right) = \tan^{-1} \left(\frac{y_1}{x_1}\right)$$

$$\Rightarrow \arg z_2 = \arg z_1$$

$$\Rightarrow \arg z_2 - \arg z_1 = 0$$

Alternate Solution

$$\because |z_1 + z_2| = |z_1| + |z_2|$$

On squaring, we get

$$|z_1 + z_2|^2 = (|z_1| + |z_2|)^2$$

$$\Rightarrow |z_1|^2 + |z_2|^2 + 2\text{Re}(z_1\bar{z}_2)$$

$$= |z_1|^2 + |z_2|^2 + 2|z_1||z_2|$$

$$\Rightarrow \text{Re}(z_1\bar{z}_2) = |z_1||z_2|$$

$$\Rightarrow |z_1||z_2| \cos(\theta_1 - \theta_2) = |z_1||z_2|$$

$$\Rightarrow \theta_1 - \theta_2 = 0$$

$$\Rightarrow \arg(z_1) - \arg(z_2) = 0$$

19. **Key Idea :** If $\left| \frac{z-z_1}{z-z_2} \right| = k$, then

z lies on a circle of $k \neq 1$ and z lies on a perpendicular bisector of segment with end points z_1 and z_2 , if $k = 1$.

Given that $w = \frac{z}{z - \frac{i}{3}}$ and $|w| = 1$

$$\Rightarrow \left| \frac{z}{z - \frac{i}{3}} \right| = 1 \Rightarrow |z| = \left| z - \frac{i}{3} \right|$$

$\Rightarrow z$ lies on \perp bisector of $(0, 0)$ and $(0, \frac{1}{3})$.

So, z lies on a straight line.

Alternate Solution

$$\therefore w = \frac{z}{z - \frac{i}{3}} \text{ and } |w| = 1$$

$$\Rightarrow \left| \frac{z}{z - \frac{i}{3}} \right| = 1$$

$$\Rightarrow 3|z| = |3z - i|$$

Let $z = x + iy$

$$\therefore 3|x + iy| = |3(x + iy) - i|$$

$$\Rightarrow 3\sqrt{x^2 + y^2} = \sqrt{(3x)^2 + (3y - 1)^2}$$

$$\Rightarrow 9x^2 + 9y^2 = 9x^2 + 9y^2 + 1 - 6y$$

$$\Rightarrow y = \frac{1}{6}$$

\therefore Which shows that z lies on a straight line.

$$20. f(x) = \begin{vmatrix} 1 + a^2 x & (1 + b^2)x & (1 + c^2)x \\ (1 + a^2)x & 1 + b^2 x & (1 + c^2)x \\ (1 + a^2)x & (1 + b^2)x & 1 + c^2 x \end{vmatrix}$$

Applying $C_1 \rightarrow C_1 + C_2 + C_3$

$$f(x) = \begin{vmatrix} 1 + a^2 x + x + b^2 x + x + c^2 x & (1 + b^2)x & (1 + c^2)x \\ x + a^2 x + 1 + b^2 x + x + c^2 x & 1 + b^2 x & (1 + c^2)x \\ x + a^2 x + x + b^2 x + 1 + c^2 x & (1 + b^2)x & 1 + c^2 x \end{vmatrix}$$

$$= \begin{vmatrix} 1 + (a^2 + b^2 + c^2 + 2)x & (1 + b^2)x & (1 + c^2)x \\ 1 + (a^2 + b^2 + c^2 + 2)x & 1 + b^2 x & (1 + c^2)x \\ 1 + (a^2 + b^2 + c^2 + 2)x & (1 + b^2)x & 1 + c^2 x \end{vmatrix}$$

$$= \begin{vmatrix} 1 & (1 + b^2)x & (1 + c^2)x \\ 1 & 1 + b^2 x & (1 + c^2)x \\ 1 & (1 + b^2)x & 1 + c^2 x \end{vmatrix}$$

$$R_1 \rightarrow R_1 - R_3, R_2 \rightarrow R_2 - R_3$$

$$= \begin{vmatrix} 0 & 0 & x - 1 \\ 0 & 1 - x & x - 1 \\ 1 & (1 + b^2)x & 1 + c^2 x \end{vmatrix}$$

$$= \begin{vmatrix} 0 & x - 1 \\ 1 - x & x - 1 \end{vmatrix}$$

$$= (x - 1)^2$$

$\Rightarrow f(x)$ is of degree 2.

21. The system of given equation has no solution, if

$$\begin{vmatrix} \alpha & 1 & 1 \\ 1 & \alpha & 1 \\ 1 & 1 & \alpha \end{vmatrix} = 0$$

$$\Rightarrow \begin{vmatrix} \alpha + 2 & 1 & 1 \\ \alpha + 2 & \alpha & 1 \\ \alpha + 2 & 1 & \alpha \end{vmatrix} = 0$$

$(C_1 \rightarrow C_1 + C_2 + C_3)$

$$\Rightarrow (\alpha + 2) \begin{vmatrix} 1 & 1 & 1 \\ 0 & \alpha - 1 & 0 \\ 0 & 0 & \alpha - 1 \end{vmatrix} = 0$$

$$(R_2 \rightarrow R_2 - R_1, R_3 \rightarrow R_3 - R_1)$$

$$\Rightarrow (\alpha + 2)(\alpha - 1)^2 = 0$$

$$\Rightarrow \alpha = 1, -2$$

But $\alpha = 1$ makes above three equations same. So, the system of equation have infinite solution. So answer is $\alpha = -2$ for which the system of equations has no solution.

22. Let α and β be the roots of equation

$$x^2 - (a - 2)x - a - 1 = 0, \text{ then}$$

$$\alpha + \beta = a - 2 \text{ and } \alpha\beta = -a - 1$$

$$\text{Now, } \alpha^2 + \beta^2 = (\alpha + \beta)^2 - 2\alpha\beta$$

$$\Rightarrow \alpha^2 + \beta^2 = (a - 2)^2 + 2(a + 1)$$

$$\Rightarrow \alpha^2 + \beta^2 = a^2 + 4 - 4a + 2a + 2$$

$$\Rightarrow \alpha^2 + \beta^2 = a^2 - 2a + 6$$

$$\Rightarrow \alpha^2 + \beta^2 = (a - 1)^2 + 5$$

The value of $\alpha^2 + \beta^2$ will be least, if $a - 1 = 0$.

$$\Rightarrow a = 1$$

Alternate Solution

$$\therefore \alpha + \beta = (a - 2) \text{ and } \alpha\beta = -a - 1$$

$$f(a) = \alpha^2 + \beta^2 = (\alpha + \beta)^2 - 2\alpha\beta = (a - 2)^2 + 2(a + 1)$$

$$= a^2 - 2a + 6$$

$$\Rightarrow f'(a) = 2a - 2$$

On putting $f'(a) = 0$ for maxima or minima.

$$\begin{aligned} \therefore 2a - 2 &= 0 \\ \Rightarrow a &= 1 \end{aligned}$$

Now $f''(a) = 2$

$$\Rightarrow f''(1) = 2 > 0$$

$\therefore f(a)$ is minimum at $a = 1$.

- 23. Key Idea :** If the roots of the equation $x^2 + bx + c = 0$ are consecutive integers, then the value of $b^2 - 4c$ is always 1.

Let n and $(n + 1)$ be the roots of $x^2 - bx + c = 0$ then $n + (n + 1) = b$ and $n(n + 1) = c$

$$\begin{aligned} \therefore b^2 - 4c &= (2n + 1)^2 - 4n(n + 1) \\ &= 4n^2 + 4n + 1 - 4n^2 - 4n \\ &= 1 \end{aligned}$$

$$\begin{aligned} 24. f'(1) &= \lim_{h \rightarrow 0} \frac{f(1+h) - f(1)}{h} \\ &= \lim_{h \rightarrow 0} \frac{f(1+h)}{h} - \lim_{h \rightarrow 0} \frac{f(1)}{h} \end{aligned}$$

Now, $\lim_{h \rightarrow 0} \frac{f(1+h)}{h} = 5$, so $\lim_{h \rightarrow 0} \frac{f(1)}{h}$ must be finite as $f'(1)$ exist and $\lim_{h \rightarrow 0} \frac{f(1)}{h}$ can be finite only, if $f(1) = 0$ and $\lim_{h \rightarrow 0} \frac{f(1)}{h} = 0$.

$$\text{So } f'(1) = \lim_{h \rightarrow 0} \frac{f(1+h)}{h} = 5.$$

- 25.** Given that, $f(1) = -2$ and $f'(x) \geq 2$

$$\begin{aligned} \Rightarrow \frac{dy}{dx} &\geq 2 \\ \Rightarrow dy &\geq 2 dx \\ \Rightarrow \int_{f(1)}^{f(6)} dy &\geq 2 \int_1^6 dx \\ \Rightarrow f(6) - f(1) &\geq 10 \\ \Rightarrow f(6) &\geq 10 + f(1) \\ \Rightarrow f(6) &\geq 8 \end{aligned}$$

Alternate Solution

$$\begin{aligned} \frac{f(6) - f(1)}{6 - 1} &\geq 2 \\ \Rightarrow f(6) - f(1) &\geq 10 \\ \Rightarrow f(6) + 2 &\geq 10 \\ \Rightarrow f(6) &\geq 8 \end{aligned}$$

$$\begin{aligned} 26. \lim_{x \rightarrow y} \frac{|f(x) - f(y)|}{|x - y|} &\leq \lim_{x \rightarrow y} |x - y| \\ \Rightarrow |f'(y)| &\leq 0 \\ \Rightarrow f'(y) &= 0 \\ \Rightarrow f(y) &= \text{constant} \\ \text{as } f(0) &= 0 \\ \Rightarrow f(y) &= 0 \\ \Rightarrow f(1) &= 0 \end{aligned}$$

$$\begin{aligned} 27. \frac{(1+x)^{3/2} - \left(1 + \frac{1}{2}x\right)^3}{(1-x)^{1/2}} \\ = \frac{\left\{1 + \frac{3}{2}x + \frac{1}{2}\left(\frac{3}{2}\right)\left(\frac{1}{2}\right)x^2 + \dots\right\} - \left(1 + \frac{3}{2}x + \frac{3}{4}x^2 + \dots\right)}{(1-x)^{1/2}} \\ = -\frac{3x^2}{8}(1-x)^{-1/2} \\ = -\frac{3x^2}{8}\left(1 + \frac{1}{2}x + \frac{1}{2}\left(\frac{3}{2}\right)\left(\frac{1}{2}\right)x^2 + \dots\right) \\ = -\frac{3x^2}{8} + \text{higher powers of } x. \\ = -\frac{3x^2}{8} \end{aligned}$$

(\therefore higher powers of x greater than x^2 can be neglected).

$$\begin{aligned} 28. \because x &= \sum_{n=0}^{\infty} a^n = 1 + a + a^2 + \dots \\ \Rightarrow x &= \frac{1}{1-a} \end{aligned}$$

Similarly,

$$y = \frac{1}{1-b} \quad \text{and} \quad z = \frac{1}{1-c}$$

Now, a, b, c are in AP

$$\begin{aligned} \Rightarrow -a, -b, -c &\text{ are also in AP.} \\ \Rightarrow 1-a, 1-b, 1-c &\text{ are also in AP.} \\ \Rightarrow \frac{1}{1-a}, \frac{1}{1-b}, \frac{1}{1-c} &\text{ are in HP.} \\ \Rightarrow x, y, z &\text{ are in HP.} \end{aligned}$$

Alternate Solution

$$\begin{aligned} \because x &= \frac{1}{1-a}, y = \frac{1}{1-b}, z = \frac{1}{1-c} \\ \Rightarrow a &= \frac{x-1}{x}, b = \frac{y-1}{y}, c = \frac{z-1}{z} \end{aligned}$$

$\because a, b, c$ are in AP

$$\begin{aligned} \therefore 2b &= a + c \\ \Rightarrow 2\left(\frac{y-1}{y}\right) &= \frac{x-1}{x} + \frac{z-1}{z} \\ \Rightarrow 2 - \frac{2}{y} &= 1 - \frac{1}{x} + 1 - \frac{1}{z} \\ \Rightarrow \frac{2}{y} &= \frac{1}{x} + \frac{1}{z} \end{aligned}$$

$\Rightarrow x, y, z$ are in HP.

$$29. \text{ We know that } \frac{c}{\sin C} = 2R$$

$$\Rightarrow c = 2R$$

... (i)

($\because C = 90^\circ$)

$$\begin{aligned} \text{and} \quad \tan \frac{C}{2} &= \frac{r}{s-c} \\ \Rightarrow \quad \tan \frac{\pi}{4} &= \frac{r}{s-c} \\ \therefore \quad r &= s-c \\ \Rightarrow \quad r &= \frac{a+b+c}{2} - c \\ \Rightarrow \quad 2r &= a+b-c \quad \dots(ii) \end{aligned}$$

On adding Eqs. (i) and (ii)

$$\Rightarrow 2(r+R) = a+b$$

30. Key Idea : $\cos^{-1} x \pm \cos^{-1} y$
 $= \cos^{-1} (xy \mp \sqrt{1-x^2} \sqrt{1-y^2})$.

We have, $\cos^{-1} x - \cos^{-1} \frac{y}{2} = \alpha$

$$\Rightarrow \cos^{-1} \left(\frac{xy}{2} + \sqrt{1-x^2} \sqrt{1-\frac{y^2}{4}} \right) = \alpha$$

$$\Rightarrow \frac{xy}{2} + \sqrt{1-x^2} \sqrt{1-\frac{y^2}{4}} = \cos \alpha$$

$$\Rightarrow 2\sqrt{1-x^2} \sqrt{1-\frac{y^2}{4}} = 2\cos \alpha - xy$$

$$\Rightarrow \frac{4(1-x^2)(4-y^2)}{4} = 4\cos^2 \alpha + x^2y^2$$

$$4 - 4x^2 - y^2 + x^2y^2 = 4\cos^2 \alpha + x^2y^2 - 4xy \cos \alpha$$

$$4 - 4x^2 - y^2 + x^2y^2 = 4\cos^2 \alpha + x^2y^2 - 2xy \cos \alpha$$

$$\Rightarrow 4x^2 - 4xy \cos \alpha + y^2 = 4\sin^2 \alpha.$$

31. Since in $\triangle ABD$

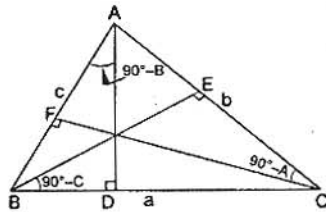

$$AD = c \cos (90^\circ - B)$$

$$AD = c \sin B$$

Similarly,

$$BE = a \sin C \text{ and } CF = b \sin A$$

$\therefore AD, BE, CF$ are in HP.

$\therefore c \sin B, a \sin C, b \sin A$ are in HP.

$$\Rightarrow \frac{1}{\sin C \sin B}, \frac{1}{\sin A \sin C}, \frac{1}{\sin B \sin A}$$

are in AP.

$\Rightarrow \sin A, \sin B, \sin C$ are in AP.

Alternate Solution

$$ar(\triangle ABC) = \frac{1}{2} \times BC \times AD$$

$$\Rightarrow \Delta = \frac{1}{2} \times a \times AD \Rightarrow AD = \frac{2\Delta}{a}$$

$$\text{Similarly, } BE = \frac{2\Delta}{b} \text{ and } CF = \frac{2\Delta}{c}$$

$\therefore AD, BE, CF$ are in HP.

$\therefore \frac{1}{a}, \frac{1}{b}, \frac{1}{c}$ are in HP.

$\Rightarrow a, b, c$ are in AP.

$\Rightarrow \sin A, \sin B, \sin C$ are in AP.

32. Key Idea : Equation of normal at any point (x_1, y_1) on any curve is

$$y - y_1 = - \frac{1}{\left(\frac{dy}{dx}\right)_{(x_1, y_1)}} (x - x_1)$$

Given that $x = a(\cos \theta + \theta \sin \theta)$

$$\frac{dx}{d\theta} = a(-\sin \theta + \sin \theta + \theta \cos \theta)$$

$$\Rightarrow \frac{dx}{d\theta} = a\theta \cos \theta$$

and $y = a(\sin \theta - \theta \cos \theta)$

$$\Rightarrow \frac{dy}{d\theta} = a(\cos \theta - \cos \theta + \theta \sin \theta)$$

$$\Rightarrow \frac{dy}{d\theta} = a\theta \sin \theta$$

$$\therefore \frac{dy}{dx} = \frac{dy/d\theta}{dx/d\theta} = \tan \theta$$

Slope of normal

$$= - \frac{dx}{dy} = - \cot \theta = \tan \left(\frac{\pi}{2} + \theta \right)$$

So equation of normal is

$$y - a \sin \theta + a \theta \cos \theta = - \frac{\cos \theta}{\sin \theta} (x - a \cos \theta - a \theta \sin \theta)$$

$$\Rightarrow \sin \theta y - a \sin^2 \theta + a \theta \cos \theta \sin \theta$$

$$= -x \cos \theta + a \cos^2 \theta + a \theta \sin \theta \cos \theta$$

$$\Rightarrow x \cos \theta + y \sin \theta = a$$

It is always at a constant distance 'a' from origin.

33. (a) $f(x) = x^3 + 6x^2 + 6$

$$f'(x) = 3x^2 + 12x = 3x(x+4)$$



$$\Rightarrow x \in (-\infty, -4) \cup (0, \infty)$$

(b) $f(x) = 3x^2 - 2x + 1$

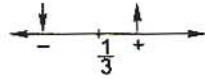

$f'(x) = 6x - 2$

$\Rightarrow f'(x) > 0 \forall x \in \left(\frac{1}{3}, \infty\right)$

This is wrong.

34.
$$\lim_{x \rightarrow \alpha} \frac{1 - \cos(ax^2 + bx + c)}{(x - \alpha)^2}$$

$$= \lim_{x \rightarrow \alpha} \frac{2 \sin^2 \left(\frac{ax^2 + bx + c}{2} \right)}{(x - \alpha)^2}$$

$$= \lim_{x \rightarrow \alpha} \frac{2 \sin^2 \left(\frac{a}{2}(x - \alpha)(x - \beta) \right)}{\left(\frac{a}{2} \right)^2 (x - \alpha)^2 (x - \beta)^2} \left(\frac{a}{2} \right)^2 (x - \beta)^2$$

$$= \lim_{x \rightarrow \alpha} \frac{a^2}{2} (x - \beta)^2 = \frac{a^2}{2} (\alpha - \beta)^2$$

$$\therefore \lim_{x \rightarrow \alpha} \frac{\sin^2 \left(\frac{a}{2}(x - \alpha)(x - \beta) \right)}{\left(\frac{a}{2}(x - \alpha)(x - \beta) \right)^2} = \frac{a^2}{2} (\alpha - \beta)^2$$

Note : If α and β are the roots of the equation $ax^2 + bx + c = 0$, then this equation can be rewritten as $a(x - \alpha)(x - \beta) = 0$.

35. $x \frac{dy}{dx} = y(\log y - \log x + 1)$

$\therefore \frac{dy}{dx} = \left(\frac{y}{x}\right) \left(\log\left(\frac{y}{x}\right) + 1\right)$

Now put $\frac{y}{x} = t$

$\Rightarrow y = tx \Rightarrow \frac{dy}{dx} = t + x \frac{dt}{dx}$

$\therefore t + x \frac{dt}{dx} = t \log t + t$

$\Rightarrow t \log t \frac{dx}{dt} = x \frac{dx}{dt}$

$\Rightarrow \frac{t \log t}{t} = \frac{x}{x}$

$\Rightarrow \log\left(\frac{y}{x}\right) = cx$

36. **Key Idea :** If L_1 and L_2 are two lines, then the equation of line passing through the point of intersection of L_1 and L_2 will be $L_1 + \lambda L_2 = 0$.

Equation of a line passing through the intersection of lines $ax + 2by + 3b = 0$ and $bx - 2ay - 3a = 0$ is

$(ax + 2by + 3b) + \lambda(bx - 2ay - 3a) = 0 \dots(i)$

Now, this line is parallel to x -axis, so coefficient of $x = 0 \Rightarrow a + \lambda b = 0 \Rightarrow \lambda = -\frac{a}{b}$.

On putting this value in Eq. (i), we get

$b(ax + 2by + 3b) - a(bx - 2ay - 3a) = 0$

$\Rightarrow 2b^2y + 3b^2 + 2a^2y + 3a^2 = 0$

$\Rightarrow 2(b^2 + a^2)y + 3(b^2 + a^2) = 0$

$\Rightarrow y = -\frac{3}{2}$

Therefore the required line is below x -axis, at a distance $\frac{3}{2}$ from it.

Alternate Solution

Equations of given lines are

$ax + 2by + 3b = 0 \dots(i)$

and $bx - 2ay - 3a = 0 \dots(ii)$

On solving Eqs. (i) and (ii), we get

$x = 0, y = -\frac{3}{2}$

\therefore Point of intersection of lines is $\left(0, -\frac{3}{2}\right)$.

Also required line is parallel to x -axis,

$\therefore m = 0$

\therefore Equation of required line is

$\left(y + \frac{3}{2}\right) = 0(x - 0)$

$\Rightarrow y = -\frac{3}{2}$

Thus the required line is below x -axis at a distance $\frac{3}{2}$ from x -axis.

37. Given that $\frac{dV}{dt} = 50 \text{ cm}^3/\text{min}$

$\frac{d}{dt} \left(\frac{4}{3} \pi r^3 \right) = 50$

$\Rightarrow \frac{dr^3}{dt} = \frac{150}{4\pi}$

$\Rightarrow 3r^2 \frac{dr}{dt} = \frac{150}{4\pi}$

$\Rightarrow \frac{dr}{dt} = \frac{50}{4\pi r^2}$

$\Rightarrow \left(\frac{dr}{dt}\right)_{r=15} = \frac{50}{4\pi \times 225} = \frac{1}{18\pi} \text{ cm/min.}$

38. Let $I = \int \left(\frac{\log x - 1}{1 + (\log x)^2} \right)^2 dx$

$= \int \frac{(\log x)^2 + 1 - 2 \log x}{(1 + (\log x)^2)^2} dx$

$$\begin{aligned}
 &= \int \frac{dx}{1 + (\log x)^2} - \int \frac{2 \log x}{(1 + (\log x)^2)^2} dx \\
 &= \frac{x}{1 + (\log x)^2} + \int \frac{2 \log x}{(1 + (\log x)^2)^2} dx \\
 &\quad - \int \frac{2 \log x}{(1 + (\log x)^2)^2} dx \\
 &= \frac{x}{1 + (\log x)^2} + c
 \end{aligned}$$

39. $\lim_{x \rightarrow 2} \int_6^{f(x)} \frac{4t^3}{x-2} dt$

$$\begin{aligned}
 &= \lim_{x \rightarrow 2} \frac{\int_6^{f(x)} 4t^3 dt}{(x-2)} \\
 &= \lim_{x \rightarrow 2} \frac{4 \{f(x)\}^3}{1} f'(x) \\
 &= 4 \{f(2)\}^3 f'(2) \\
 &= 4 \times (6)^3 \times \frac{1}{48} \\
 &= 18
 \end{aligned}$$

40. $\int_{\pi/4}^{\beta} f(x) dx = \beta \sin \beta + \frac{\pi}{4} \cos \beta + \sqrt{2} \beta$

Differentiate with respect to β on both sides

$$f(\beta) = \sin \beta + \beta \cos \beta - \frac{\pi}{4} \sin \beta + \sqrt{2}$$

So, $f\left(\frac{\pi}{2}\right) = 1 + 0 - \frac{\pi}{4} + \sqrt{2} = 1 - \frac{\pi}{4} + \sqrt{2}$

41. $I_1 = \int_0^1 2^{x^2} dx$, $I_2 = \int_0^1 2^{x^3} dx$,

$$I_3 = \int_1^2 2^{x^2} dx \text{ and } I_4 = \int_1^2 2^{x^3} dx$$

$\therefore \begin{matrix} 2^{x^3} < 2^{x^2} & 0 < x < 1 \\ 2^{x^3} > 2^{x^2} & x > 1 \end{matrix}$

$\therefore I_2 < I_1$ and $I_4 > I_3$

42. Required area $A = \int_{1-e}^0 \log_e(x+e) dx$

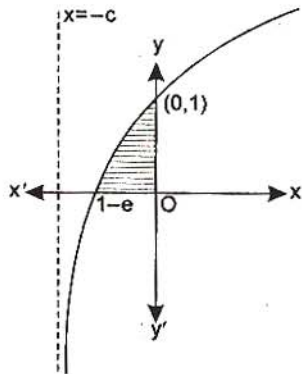

Put $x + e = t \Rightarrow dx = dt$

$$\begin{aligned}
 \therefore A &= \int_1^e \log_e t dt = [t \log t - t]_1^e \\
 &= (e - e - 0 + 1) = 1
 \end{aligned}$$

43. **Key Idea** : Area of region bounded by $y^2 = 4ax$ and $y^2 = 4by$ is $\frac{16ab}{3}$ sq unit.

Now, $S_1 = S_3 = \int_0^4 \frac{x^2}{4} dx$

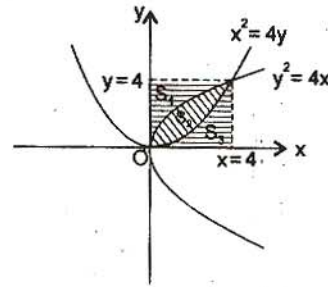

$$\begin{aligned}
 &= \frac{1}{4} \left[\frac{x^3}{3} \right]_0^4 \\
 &= \frac{1}{12} \times 64 = \frac{16}{3} \text{ sq unit}
 \end{aligned}$$

$$\begin{aligned}
 \therefore S_2 + S_3 &= \int_0^4 \sqrt{4x} dx \\
 &= 2 \times 2 \left[\frac{x^{3/2}}{3} \right]_0^4 = \frac{4}{3} \times 8 \\
 &= \frac{32}{3} \text{ sq unit} \\
 \Rightarrow S_2 &= \frac{16}{3} \text{ sq unit} \\
 \therefore S_1 : S_2 : S_3 &= \frac{16}{3} : \frac{16}{3} : \frac{16}{3} = 1 : 1 : 1
 \end{aligned}$$

44. **Key Idea** : Centre of sphere $x^2 + y^2 + z^2 + 2ux + 2vy + 2wz + d = 0$ is $(-u, -v, -w)$.

Equation of first sphere is

$$x^2 + y^2 + z^2 + 6x - 8y - 2z = 13 \quad \dots(i)$$

whose centre is $(-3, 4, 1)$

and equation of second sphere is

$$x^2 + y^2 + z^2 - 10x + 4y - 2z = 8 \quad \dots(ii)$$

whose centre is $(5, -2, 1)$.

Mid point of $(-3, 4, 1)$ and $(5, -2, 1)$ is $(1, 1, 1)$.

Since, the plane passes through $(1, 1, 1)$.

$$\therefore 2a - 3a + 4a + 6 = 0$$

$$\Rightarrow 3a = -6 \Rightarrow a = -2$$

45. Line is parallel to plane as

$$(\hat{i} - \hat{j} + 4\hat{k}) \cdot (\hat{i} + 5\hat{j} + \hat{k}) = 0.$$

General point on the line is $(\lambda + 2, -\lambda - 2, 4\lambda + 3)$. For $\lambda = 0$ a point on this line is $(2, -2, 3)$ and distance from

$$\vec{r} \cdot (\hat{i} + 5\hat{j} + \hat{k}) = 5 \text{ or } x + 5y + z = 5$$

$$d = \frac{|2 + 5(-2) + 3 - 5|}{\sqrt{1 + 25 + 1}}$$

$$\Rightarrow d = \frac{|-10|}{3\sqrt{3}} = \frac{10}{3\sqrt{3}}$$

46. Since $(\vec{a} \times \hat{i}) \cdot (\vec{a} \times \hat{i}) = \begin{vmatrix} \vec{a} \cdot \vec{a} & \vec{a} \cdot \hat{i} \\ \hat{i} \cdot \vec{a} & 1 \end{vmatrix}$

$$= |\vec{a}|^2 - a_1^2$$

Similarly, $(\vec{a} \times \hat{j})^2 = |\vec{a}|^2 - a_2^2$

and $(\vec{a} \times \hat{k})^2 = |\vec{a}|^2 - a_3^2$

$$\begin{aligned} \therefore (\vec{a} \times \hat{i})^2 + (\vec{a} \times \hat{j})^2 + (\vec{a} \times \hat{k})^2 &= 3|\vec{a}|^2 - (a_1^2 + a_2^2 + a_3^2) \\ &= 3|\vec{a}|^2 - |\vec{a}|^2 \\ &= 2|\vec{a}|^2 = 2\vec{a} \cdot \vec{a} \end{aligned}$$

Alternate Solution

Let $\vec{a} = a_1\hat{i} + a_2\hat{j} + a_3\hat{k}$

$$|\vec{a}|^2 = a_1^2 + a_2^2 + a_3^2$$

and $\vec{a} \times \hat{i} = (a_1\hat{i} + a_2\hat{j} + a_3\hat{k}) \times \hat{i}$
 $= -a_2\hat{k} + a_3\hat{j}$

$$(\vec{a} \times \hat{i})^2 = a_2^2 + a_3^2$$

Similarly, $(\vec{a} \times \hat{j})^2 = a_3^2 + a_1^2$

and $(\vec{a} \times \hat{k})^2 = a_1^2 + a_2^2$

$$\begin{aligned} \therefore (\vec{a} \times \hat{i})^2 + (\vec{a} \times \hat{j})^2 + (\vec{a} \times \hat{k})^2 &= (a_2^2 + a_3^2 + a_3^2 + a_1^2 + a_1^2 + a_2^2) \\ &= 2(a_1^2 + a_2^2 + a_3^2) \\ &= 2|\vec{a}|^2 \end{aligned}$$

47. $\because a, b, c$ are in HP

$$\frac{2}{b} = \frac{1}{a} + \frac{1}{c}$$

$$\Rightarrow \frac{1}{a} - \frac{2}{b} + \frac{1}{c} = 0$$

So straight line $\frac{x}{a} + \frac{y}{b} + \frac{z}{c} = 0$ always passes through a fixed point $(1, -2)$.

48. **Key Idea :** If $A(x_1, y_1)$, $B(x_2, y_2)$ and $C(x_3, y_3)$ are the vertices of a triangle, then the co-ordinates of the centroid will be $\left(\frac{x_1 + x_2 + x_3}{3}, \frac{y_1 + y_2 + y_3}{3}\right)$.

Let D and E are mid points of AB and AC . So co-ordinates of B and C are $(-3, 3)$ and $(5, 3)$ respectively.

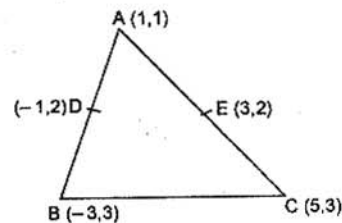

Centroid of triangle

$$\begin{aligned} &= \left(\frac{x_1 + x_2 + x_3}{3}, \frac{y_1 + y_2 + y_3}{3}\right) \\ &= \left(\frac{1 - 3 + 5}{3}, \frac{1 + 3 + 3}{3}\right) \\ &= \left(1, \frac{7}{3}\right) \end{aligned}$$

49. **Key Idea :** If $S_1 = 0$ and $S_2 = 0$ are two circles, then the equation of line passes through the points of intersection of $S_1 = 0$ and $S_2 = 0$, is $S_1 - S_2 = 0$.

Equation of circles are

$$S_1 \equiv x^2 + y^2 + 2ax + cy + a = 0$$

$$\text{and } S_2 \equiv x^2 + y^2 - 3ax + dy - 1 = 0$$

respectively.

Chord through intersection points P and Q of the circles $S_1 = 0$ and $S_2 = 0$ is $S_1 - S_2 = 0$.

$$\therefore 5ax + (c - d)y + a + 1 = 0$$

On comparing it with $5x + by - a = 0$, we get

$$\frac{5a}{5} = \frac{c - d}{b} = \frac{a + 1}{-a}$$

$$\Rightarrow a(-a) = a + 1 \Rightarrow a^2 + a + 1 = 0$$

Which gives no real value of a .

\therefore The line will pass through P and Q for no value of a .

50. Since circle touches the x-axis and also touches circle with the centre at (0, 3) and radius 2, then

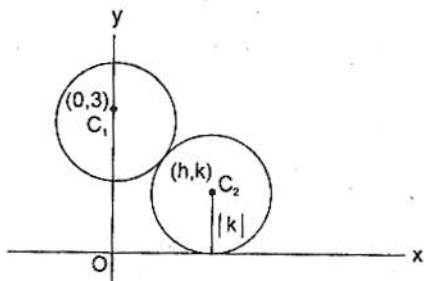

$$C_1 C_2 = r_1 + r_2$$

$$h^2 + (k - 3)^2 = (|k| + 2)^2$$

$$h^2 + k^2 + 9 - 6k = k^2 + 4 + 4|k|$$

∴ Locus of centre of circle is

$$x^2 = -5 + 6y + 4|y|$$

$$x^2 = 10y - 5 \quad (\because y > 0)$$

This equation represents a parabola. Thus locus of the centre of the circle is a parabola.

51. **Key Idea :** Two circles

$$x^2 + y^2 + 2g_1x + 2f_1y + c_1 = 0$$

and $x^2 + y^2 + 2g_2x + 2f_2y + c_2 = 0$ cuts orthogonally, then

$$2g_1g_2 + 2f_1f_2 = c_1 + c_2.$$

Let the circle is $x^2 + y^2 + 2gx + 2fy + c = 0$, It cuts circle $x^2 + y^2 = p^2$ orthogonally.

So, $c = p^2$ and it passes through (a, b).

$$a^2 + b^2 + 2ga + 2fb + p^2 = 0$$

So, locus of $(-g, -f)$ is

$$a^2 + b^2 - 2ax - 2by + p^2 = 0$$

$$\Rightarrow 2ax + 2by - (a^2 + b^2 + p^2) = 0$$

Alternate Solution

Let the centre of required circle is $(-g, -f)$. This circle cut the circle $x^2 + y^2 = p^2$ orthogonally. The centre and radius of circle $x^2 + y^2 = p^2$ are (0, 0) and p respectively.

$$\therefore g^2 + f^2 = p^2 + (a + g)^2 + (b + f)^2$$

$$\Rightarrow g^2 + f^2 = p^2 + a^2 + g^2 + 2ag + b^2 + f^2 + 2bf$$

$$\Rightarrow p^2 + a^2 + b^2 + 2ag + 2bf = 0$$

Thus the locus of centre is

$$2ax + 2by - (a^2 + b^2 + p^2) = 0$$

52. $\angle FBF' = 90^\circ \Rightarrow \angle OBF' = 45^\circ$

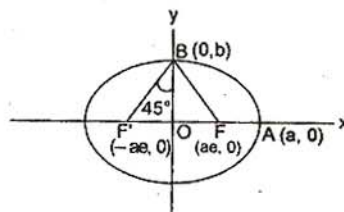

$$\Rightarrow ae = b$$

and

$$e^2 = 1 - \frac{b^2}{a^2}$$

$$\Rightarrow e^2 = 1 - \frac{a^2 e^2}{a^2}$$

$$\Rightarrow e^2 = 1 - e^2$$

$$\Rightarrow 2e^2 = 1$$

$$\Rightarrow e = \frac{1}{\sqrt{2}}$$

Alternate Solution

∴ F and F' are foci of an ellipse, whose co-ordinates are (ae, 0) and (-ae, 0) respectively and co-ordinates of B are (0, b).

$$\therefore \text{Slope of } BF = \frac{b}{-ae}$$

$$\text{and slope of } BF' = \frac{b}{ae}$$

$$\because \angle FBF' = 90^\circ$$

$$\therefore -\frac{b}{ae} \cdot \left(\frac{b}{ae}\right) = -1$$

$$\Rightarrow b^2 = a^2 e^2$$

$$\therefore e^2 = 1 - \frac{b^2}{a^2} = 1 - \frac{a^2 e^2}{a^2}$$

$$\Rightarrow 2e^2 = 1 \Rightarrow e = \frac{1}{\sqrt{2}}$$

53. **Key Idea :** A line $y = mx + c$ is tangent to

$$\text{hyperbola } \frac{x^2}{a^2} - \frac{y^2}{b^2} = 1, \text{ if } c^2 = a^2 m^2 - b^2.$$

Line $y = \alpha x + \beta$ is tangent, if $\beta^2 = a^2 \alpha^2 - b^2$.

So locus of (α, β) is $y^2 = a^2 x^2 - b^2$

$$\Rightarrow a^2 x^2 - y^2 - b^2 = 0$$

Since this equation represents a hyperbola, so locus of a point $P(\alpha, \beta)$ is a hyperbola.

54. Since the angle between the line and plane is same as angle between the line and normal to the plane

$$\sin \theta = \frac{(\hat{i} + 2\hat{j} + 2\hat{k}) \cdot (2\hat{i} - \hat{j} + \sqrt{\lambda}\hat{k})}{3\sqrt{4+1+\lambda}} = \frac{1}{3}$$

$$\Rightarrow 2 - 2 + 2\sqrt{\lambda} = \sqrt{5 + \lambda}$$

$$\begin{aligned} \Rightarrow 4\lambda &= 5 + \lambda \\ \Rightarrow 3\lambda &= 5 \\ \Rightarrow \lambda &= \frac{5}{3} \end{aligned}$$

Note : The angle between a line $\frac{x-x_1}{a_1} = \frac{y-y_1}{b_1} = \frac{z-z_1}{c_1}$ and a plane $a_2x + b_2y + c_2z + d_2 = 0$ is given by

$$\sin \theta = \frac{|a_1a_2 + b_1b_2 + c_1c_2|}{\sqrt{a_1^2 + b_1^2 + c_1^2} \sqrt{a_2^2 + b_2^2 + c_2^2}}$$

55. The given equations can be rewritten as

$$\frac{x}{3} = \frac{y}{2} = \frac{z}{-6} \quad \text{and} \quad \frac{x}{2} = \frac{y}{-12} = \frac{z}{-3}$$

\therefore Angle between the lines is given by

$$\begin{aligned} \cos \theta &= \frac{6 - 24 + 18}{\sqrt{9+4+36} \sqrt{4+144+9}} \\ &= \frac{0}{\sqrt{49} \sqrt{157}} = 0 \end{aligned}$$

$$\Rightarrow \theta = 90^\circ$$

Note : If a_1, b_1, c_1 and a_2, b_2, c_2 are d.r.'s. of two lines then the angled between them is given by

$$\cos \theta = \frac{a_1a_2 + b_1b_2 + c_1c_2}{\sqrt{a_1^2 + b_1^2 + c_1^2} \sqrt{a_2^2 + b_2^2 + c_2^2}}$$

56. Given that

$$P(\overline{A \cup B}) = \frac{1}{6}, \quad P(A \cap B) = \frac{1}{4}, \quad P(\overline{A}) = \frac{1}{4}$$

$$\therefore P(\overline{A \cup B}) = \frac{1}{6}$$

$$\Rightarrow 1 - P(A \cup B) = \frac{1}{6}$$

$$\Rightarrow 1 - P(A) - P(B) + P(A \cap B) = \frac{1}{6}$$

$$\Rightarrow P(\overline{A}) - P(B) + \frac{1}{4} = \frac{1}{6}$$

$$\Rightarrow P(B) = \frac{1}{4} + \frac{1}{4} - \frac{1}{6}$$

$$\Rightarrow P(B) = \frac{1}{3} \quad \text{and} \quad P(A) = \frac{3}{4}$$

Clearly $P(A \cap B) = P(A)P(B)$ so the events A and B are independent events but not equally likely.

Note : Two events A and B are said to be equally likely, if $P(A) = P(B)$ and known as independent events, if $P(A \cap B) = P(A)P(B)$.

57. Person 1 has three options to apply.

Similarly, person 2 has three options to apply and person 3 has three options to apply.

$$\text{Total cases} = 3^3$$

Now, favourable cases = 3 (An either all has applied for house 1 or 2 or 3)

$$\text{So probability} = \frac{3}{3^3} = \frac{1}{9}$$

58. **Key Idea :** In a poisson distribution,

$$P(X=r) = \frac{e^{-\lambda} \lambda^r}{r!} \quad (\lambda = \text{mean})$$

$$\begin{aligned} \therefore P(X=r > 1.5) &= P(2) + P(3) + \dots \infty \\ &= 1 - (P(0) + P(1)) \\ &= 1 - \left(e^{-2} + \frac{e^{-2} \times 2}{1} \right) = 1 - \frac{3}{e^2} \end{aligned}$$

59. **Key Idea :** If u is initial velocity of any particle and a is a acceleration, then

$$v = u + at$$

where v is a speed of particle after t seconds.

$$\text{We have} \quad v_A = f(t+m) \quad \dots(i)$$

$$v_B = f't \quad \dots(ii)$$

$$\text{Now,} \quad v_A = v_B \Rightarrow f't = f(t+m) \quad \dots(iii)$$

$$S + n = \frac{1}{2} f(t+m)^2 \quad \dots(iv)$$

$$S = \frac{1}{2} f't^2 \quad \dots(v)$$

$$n = \frac{1}{2} f(t+m)^2 - \frac{1}{2} f't^2 \quad \dots(vi)$$

$$\Rightarrow n = \frac{1}{2} \frac{f(f't)^2}{f^2} - \frac{1}{2} f't^2$$

$$\Rightarrow 2nf = ((f')^2 - f f') t^2$$

$$\Rightarrow t^2 = \frac{2nf}{f'(f'-f)} \quad \dots(vii)$$

From Eq. (iii)

$$t = \frac{fm}{(f'-f)} \quad \dots(viii)$$

So from Eqs. (vii) and (viii)

$$\frac{f^2 m^2}{(f'-f)^2} = \frac{2nf}{f'(f'-f)}$$

$$\Rightarrow f' f m^2 = 2n(f'-f)$$

60. Let lizard catch the insect C

and distance covered by insect = S

$$\text{time taken by insect, } t = \frac{S}{20} \quad \dots(i)$$

Distance covered by lizard = $21 + S$

$$21 + S = \frac{1}{2} (20)t^2 \quad \dots(ii)$$

$$\Rightarrow 21 + 20t = t^2 \quad (\text{using Eq. (i)})$$

$$\Rightarrow t^2 - 20t - 21 = 0$$

$$\Rightarrow t^2 - 21t + t - 21 = 0$$

$$\Rightarrow t(t-21) + 1(t-21) = 0$$

$$\Rightarrow (t+1)(t-21) = 0$$

$$\Rightarrow t = 21 \text{ s.}$$

61. **Key Idea :** If R is a resultant of two forces P and Q acting on a particle, then

$$P = \frac{R \sin \beta}{\sin(\alpha + \beta)} \quad \text{and} \quad Q = \frac{R \sin \alpha}{\sin(\alpha + \beta)}$$

Given that $R = \frac{Q}{3}$
 $P = \frac{R \sin \theta}{\sin(90^\circ + \theta)}$ and $Q = \frac{R \sin 90^\circ}{\sin(90^\circ + \theta)}$

$\Rightarrow Q = \frac{Q}{3 \cos \theta}$

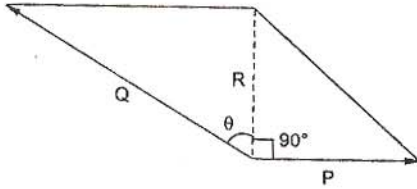

$\Rightarrow \cos \theta = \frac{1}{3} \Rightarrow \sin \theta = \sqrt{1 - \frac{1}{9}} = \frac{2\sqrt{2}}{3}$

$\therefore P = \frac{3R \sin \theta}{1} = \frac{3R \cdot 2\sqrt{2}}{3}$

$\Rightarrow P = 2\sqrt{2}R$

$\therefore \frac{P}{Q} = \frac{2\sqrt{2}R}{\frac{R}{3}} = 2\sqrt{2} : 3$

$\Rightarrow \frac{Q}{P} = 3 : 2\sqrt{2}$

62. **Key Idea** : If $\vec{a} = a_1\hat{i} + a_2\hat{j} + a_3\hat{k}$,
 $\vec{b} = b_1\hat{i} + b_2\hat{j} + b_3\hat{k}$ and $\vec{c} = c_1\hat{i} + c_2\hat{j} + c_3\hat{k}$

$\therefore [\vec{a} \vec{b} \vec{c}] = \begin{vmatrix} a_1 & a_2 & a_3 \\ b_1 & b_2 & b_3 \\ c_1 & c_2 & c_3 \end{vmatrix}$

$[\vec{a} \vec{b} \vec{c}] = \begin{vmatrix} 1 & 0 & -1 \\ x & 1 & 1-x \\ y & x & 1+x-y \end{vmatrix}$

Applying $C_3 \rightarrow C_3 + C_1$

$$= \begin{vmatrix} 1 & 0 & 0 \\ x & 1 & 1 \\ y & x & 1+x \end{vmatrix}$$

$$= \begin{vmatrix} 1 & 1 \\ x & 1+x \end{vmatrix}$$

$$= 1(1+x) - x = 1$$

Thus $[\vec{a} \vec{b} \vec{c}]$ does not depend upon neither x nor y .

63. **Key Idea** : If three vectors \vec{a} , \vec{b} and \vec{c} are coplanar, then $[\vec{a} \vec{b} \vec{c}] = 0$.

The given points lies in a plane, if

$\begin{vmatrix} a & a & c \\ 1 & 0 & 1 \\ c & c & b \end{vmatrix} = 0 \quad (C_1 \rightarrow C_1 - C_2)$

$\Rightarrow \begin{vmatrix} 0 & a & c \\ 1 & 0 & 1 \\ 0 & c & b \end{vmatrix} = 0$

$\Rightarrow -1 \begin{vmatrix} a & c \\ c & b \end{vmatrix} = 0$

$\Rightarrow c^2 - ab = 0$, Therefore c is GM of a and b .

64.
$$\begin{vmatrix} \lambda(a_1 + b_1) & \lambda(a_2 + b_2) & \lambda(a_3 + b_3) \\ \lambda^2 b_1 & \lambda^2 b_2 & \lambda^2 b_3 \\ \lambda c_1 & \lambda c_2 & \lambda c_3 \end{vmatrix}$$

$$= \begin{vmatrix} a_1 & a_2 & a_3 \\ b_1 + c_1 & b_2 + c_2 & b_3 + c_3 \\ b_1 & b_2 & b_3 \end{vmatrix}$$

$$\Rightarrow \lambda^4 \begin{vmatrix} a_1 & a_2 & a_3 \\ b_1 & b_2 & b_3 \\ c_1 & c_2 & c_3 \end{vmatrix} = - \begin{vmatrix} a_1 & a_2 & a_3 \\ b_1 & b_2 & b_3 \\ c_1 & c_2 & c_3 \end{vmatrix}$$

$$\Rightarrow \lambda^4 = -1$$

So, no real value of λ exists.

Alternate Solution

$[\lambda(\vec{a} + \vec{b}) \lambda^2 \vec{b} \lambda \vec{c}] = [\vec{a} \vec{b} + \vec{c} \vec{b}]$

$\Rightarrow \lambda(\vec{a} + \vec{b}) \cdot (\lambda^2 \vec{b} \times \lambda \vec{c}) = \vec{a} \cdot ((\vec{b} + \vec{c}) \times \vec{b})$

$\Rightarrow \lambda^4 (\vec{a} + \vec{b}) \cdot (\vec{b} \times \vec{c}) = \vec{a} \cdot (\vec{c} \times \vec{b})$

$\Rightarrow \lambda^4 \{\vec{a} \cdot (\vec{b} \times \vec{c})\} = -\{\vec{a} \cdot (\vec{b} \times \vec{c})\}$

$\Rightarrow \lambda^4 = -1 \quad (\because [\vec{a} \vec{b} \vec{c}] \neq 0)$

\Rightarrow No real value of λ exists.

65. Let the resultant of A and B is displaced by x . Then change in net momentum of A and $B =$ applied momentum

$\therefore Ax + Bx = H$

$\Rightarrow x = \frac{H}{A+B}$

66. We know that

$e^x = 1 + x + \frac{x^2}{2!} + \frac{x^3}{3!} + \frac{x^4}{4!} + \dots$

$e^{-x} = 1 - x + \frac{x^2}{2!} - \frac{x^3}{3!} + \frac{x^4}{4!} - \dots$

$\Rightarrow \frac{e^x + e^{-x}}{2} = 1 + \frac{x^2}{2!} + \frac{x^4}{4!} + \frac{x^6}{6!} + \dots$

Put $x = \frac{1}{2}$

$\frac{e^{1/2} + e^{-1/2}}{2} = 1 + \left(\frac{1}{2}\right)^2 \frac{1}{2!} + \left(\frac{1}{2}\right)^4 \frac{1}{4!} + \dots$

$\Rightarrow \frac{e+1}{2\sqrt{e}} = 1 + \left(\frac{1}{2}\right)^2 \frac{1}{2!} + \left(\frac{1}{2}\right)^4 \frac{1}{4!} + \dots$

67. If $a > 0$, $i = 1, 2, 3, \dots, n$ which are not identical, then

AM of m th power $>$ m th power of AM, if $m > 1$

$\Rightarrow \frac{x_1^2 + x_2^2 + \dots + x_n^2}{n} > \left(\frac{x_1 + x_2 + \dots + x_n}{n}\right)^2$

$$\Rightarrow \frac{\sum_{i=1}^n x_i^2}{n} > \left(\frac{\sum_{i=1}^n x_i}{n} \right)^2$$

$$\Rightarrow \frac{400}{n} > \left(\frac{80}{n} \right)^2$$

$$\Rightarrow \frac{n^2}{n} > \frac{80^2}{400}$$

$$\Rightarrow n > 16$$

68. Given $\vec{u} \perp \vec{v}$
 \vec{u} is making an angle 60° with horizontal (upwards).
 Therefore \vec{v} should be at 30° with horizontal (downward) as shown in fig.

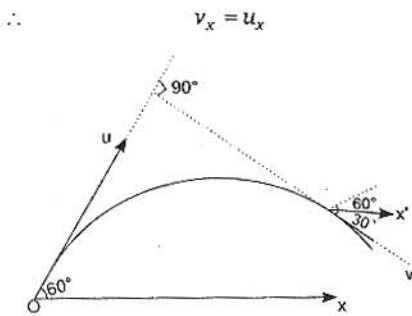

$$\therefore v_x = u_x$$

$$\therefore v \cos 30^\circ = u \cos 60^\circ$$

$$\Rightarrow \frac{\sqrt{3}v}{2} = u \cdot \frac{1}{2}$$

$$\Rightarrow v = \frac{u}{\sqrt{3}}$$

69. **Key Idea :** If both roots of $ax^2 + bx + c = 0$ are less than α , then $b^2 - 4ac \geq 0$, $f(\alpha) > 0$ and $-\frac{b}{2a} < \alpha$.

$$\text{Let } f(x) = x^2 - 2kx + k^2 + k - 5$$

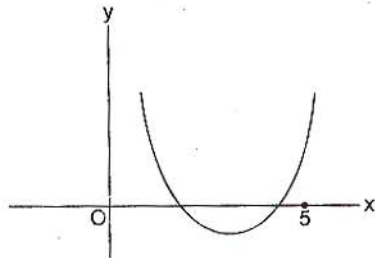

$$\therefore D = 4k^2 - 4(k^2 + k - 5)$$

$$= -4k + 20 \geq 0$$

$$\Rightarrow k \leq 5 \quad \dots(i)$$

$$\text{Also } -\frac{b}{2a} < 5 \quad \dots(ii)$$

$$\text{and } f(5) > 0 \quad \dots(iii)$$

$$\text{From (ii), } k < 5 \quad \dots(iv)$$

$$\text{From (iii), } 25 - 10k + k^2 + k - 5 > 0$$

$$\Rightarrow k^2 - 9k + 20 > 0$$

$$\Rightarrow k^2 - 5k - 4k + 20 > 0$$

$$\Rightarrow (k - 5)(k - 4) > 0$$

$$\Rightarrow k < 4 \text{ and } k > 5 \quad \dots(v)$$

$$\text{From (i), (iii) and (iv)}$$

$$\Rightarrow k < 4$$

70. Since, $a_1, a_2, \dots, a_n, \dots$ are in GP. then $\log a_n, \log a_{n+1}, \log a_{n+2}, \dots, \log a_{n+8}$ are in AP.

$$\text{So, } \Delta = \begin{vmatrix} a & a+d & a+2d \\ a+3d & a+4d & a+5d \\ a+6d & a+7d & a+8d \end{vmatrix}$$

$$\text{Applying } \begin{matrix} C_2 \rightarrow C_2 - C_1 \\ C_3 \rightarrow C_3 - C_1 \end{matrix}$$

$$\Delta = \begin{vmatrix} a & d & 2d \\ a+3d & d & 2d \\ a+6d & d & 2d \end{vmatrix} = 0$$

(Since two columns are similar)

71. Given $f(x-y) = f(x)f(y) - f(a-x)f(a+y)$

$$\text{Let } x = 0 = y$$

$$\Rightarrow f(0) = (f(0))^2 - (f(a))^2$$

$$\Rightarrow 1 = 1 - (f(a))^2$$

$$\Rightarrow f(a) = 0$$

$$\therefore f(2a-x) = f(a-(x-a))$$

$$= f(a)f(x-a) - f(a-a)f(x)$$

$$= 0 - f(x) \cdot 1$$

$$= -f(x)$$

72. Let $f(x) = a_n x^n + a_{n-1} x^{n-1} + \dots + a_1 x = 0$,
 $a_1 \neq 0$

It has roots $x = 0$ and $\alpha > 0$

$$f'(x) = na_n x^{n-1} + (n-1)a_{n-1} x^{n-2}$$

$$+ \dots + a_1 = 0$$

So definitely its derivative is zero between 0 and α .

So, $f'(x)$ has a positive root smaller than α .

73. Let $I = \int_{-\pi}^{\pi} \frac{\cos^2 x}{1 + a^x} dx, a > 0 \quad \dots(i)$

$$I = \int_{-\pi}^{\pi} \frac{\cos^2 x}{1 + a^{-x}} dx \quad \dots(ii)$$

On adding Eqs. (i) and (ii)

$$\Rightarrow 2I = \int_{-\pi}^{\pi} \frac{(1 + a^x) \cos^2 x}{(1 + a^x)} dx$$

$$\begin{aligned} \Rightarrow 2I &= \int_{-\pi}^{\pi} \cos^2 x \, dx \\ \Rightarrow 2I &= \int_{-\pi}^{\pi} \left(\frac{\cos 2x + 1}{2} \right) dx \\ &= \frac{1}{2} \left[\left(\frac{\sin 2x}{2} + x \right) \right]_{-\pi}^{\pi} \\ \Rightarrow 2I &= \frac{1}{2} (\pi + \pi) \\ \Rightarrow I &= \frac{\pi}{2} \end{aligned}$$

74. Since the centre of sphere

$$x^2 + y^2 + z^2 - x + z - 2 = 0 \text{ is } \left(\frac{1}{2}, 0, -\frac{1}{2} \right) \text{ and}$$

radius of sphere

$$= \sqrt{\frac{1}{4} + \frac{1}{4} + 2} = \frac{\sqrt{10}}{2}$$

Distance of plane from centre of sphere

$$= \frac{\left| \frac{1}{2} + \frac{1}{2} - 4 \right|}{\sqrt{1 + 4 + 1}} = \frac{3}{\sqrt{6}}$$

$$\begin{aligned} \text{So radius of circle} &= \sqrt{\frac{10}{4} - \frac{9}{6}} \\ &= \sqrt{\frac{30 - 18}{12}} = \sqrt{\frac{12}{12}} = 1 \end{aligned}$$

75. Equation of pair of lines is $ax^2 + 2(a+b)xy + by^2 = 0$

$$\text{Since } 4\theta = \pi \Rightarrow \theta = \frac{\pi}{4}$$

Angle between lines is given by

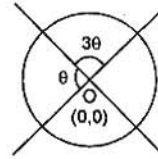

$$\tan \theta = \frac{2\sqrt{H^2 - AB}}{|A + B|}$$

$$\Rightarrow 1 = \frac{2\sqrt{(a+b)^2 - ab}}{|a+b|}$$

$$\Rightarrow a^2 + b^2 + 2ab = 4(a^2 + b^2 + ab)$$

$$\Rightarrow 3a^2 + 3b^2 + 2ab = 0$$